



The Original And Best Since 1902

For over 100 years, Sturmey-Archer have been pioneers in the design and manufacture of internal gear hubs, hub brakes and dynohub lighting.

This is a history of progressive research and development which has made cycling easier and safer.

This catalogue illustrates the complete range of Sturmey-Archer cycle components, including the latest innovations.

www.sturmey-archer.com

www.sturmey-archerheritage.com



Henry Sturmey



James Archer



STURMEY-ARCHER



1902
3-Speed Hub



1907
3-Speed Coaster



1910
X Gear Control



1910
Catalogue



1913
Tour de France



1918
KB 3-Speed
Drum Brake



1922
CC Single
Speed Coaster



1922
K Gear Control



1929
Nürnberg, Germany



1931
Motorcycle
Gearbox Ad



1933
TF 2-Speed Fixed



1938
Dynohub & TF 4-Speed



1939
Trigger Control



1946
ASC 3-Speed
Fixed



1951
Dry Battery Unit

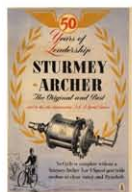

1952
50 Years Poster



1953
The Original And Best
Poster



1955
Amsterdam, NL



1962
London-Cardiff
Record



1966
S5 5-Speed



1966
S2 Kick-Shift



1968
Chopper Shifters



1970
Lights



1972
Girl Poster



1977
SBF Front Drum Brake



1978
SAB 3-Speed
Drum Brake



1983
Dutch Ad



1983
S5/2 Alloy
5-Speed



1984
VT 70mm Front & AT3 3-Speed
70mm Rear



1985
Shifters



1988
AWC with Brass Brake



1992
Joint Trade Ad



1995
AT5 5-Speed
Drum Brake



1997
AT7 7-Speed
Drum Brake



1997
Orion Shifter



1999
Summit Series



2000
New Home Advert



FCSA3 33T (2mm) FCSB8 38T (3mm)
 FCSA6 36T (2mm)
 FCSA8 38T (2mm)

- › New cranksets specifically designed for closed chain cases with 95mm cover diameter. Featuring aluminum crank arms with steel chainrings.



HBT30-R

- › New fixed/freewheel hub with high polished anodized hub shell, available in 6 colors. Featuring sealed cartridge bearings and chromoly axle.



SLS50 H[31.8mm] / P[27.2mm]
 SLS30 H[31.8mm] / P[27.2mm]
 SLS3X H[31.8mm] / P[27.2mm]

- › Thumb shifters now available with 31.8mm and 27.2mm clamps to accommodate mounting on oversized handlebars or seat posts.

XL-FDD X-FDD
Sturmeier Archer

Dynohub Drum Brake

P.6



580 (W)

8 Speed Hubs

P.8



550 (W), 555 (W)

5 Speed Hubs

P.11



C30

Rotary 3 Speed Hubs

P.16



530, 535

Classic 3 Speed Hubs

P.19



5X, T5, Q5

Cruiser, Tricycle, Quadricycle Hubs P.22



53X

Fixed 3 Speed, HBT Hubs P.24



F30

Cassette Freehub 3 Speed P.28



520, 525

2 Speed Kick Shift P.30



Drum Brake Hubs

Front, Rear, and Side Hubs P.32



Front Cranksets

FCS, FCT

P.34



Parts

P.38



Specifications

Dynohub Drum Brake	P.48	Cassette Freehub 3 Speed	P.65
Brake Levers	P.48	2 Speed Kick Shift Hubs ..	P.66
Shifters	P.49	HBT Hubs	P.67
8 Speed Hubs	P.54	Drum Brake Hubs	P.68
5 Speed Hubs	P.55	Front Cranksets FCS	P.71
Rotary 3 Speed Hubs	P.58	Front Cranksets FCT	P.73
3 Speed Hubs	P.59	Bottom Brackets	P.75
Cruiser, Tricycle, Quadricycle	P.62	Chain Tensioner	P.75
Fixed 3 Speed Hubs	P.64	Chain	P.76

- World's first integrated dynohub & drum brake.
- 90mm and 70mm drum brake dynohub version available.
- 2.4W and 3.0W versions available in both drum brake sizes.
- Totally sealed against weather conditions.
- Constructed with sealed cartridge bearings.
- Low rolling resistance.

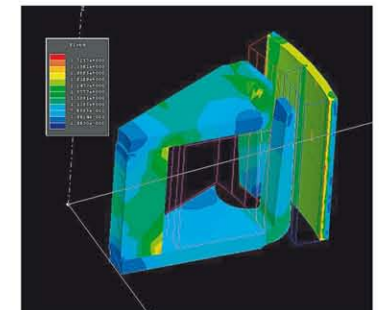
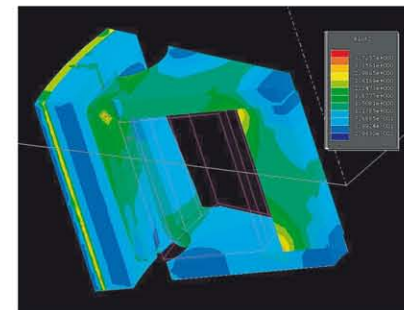
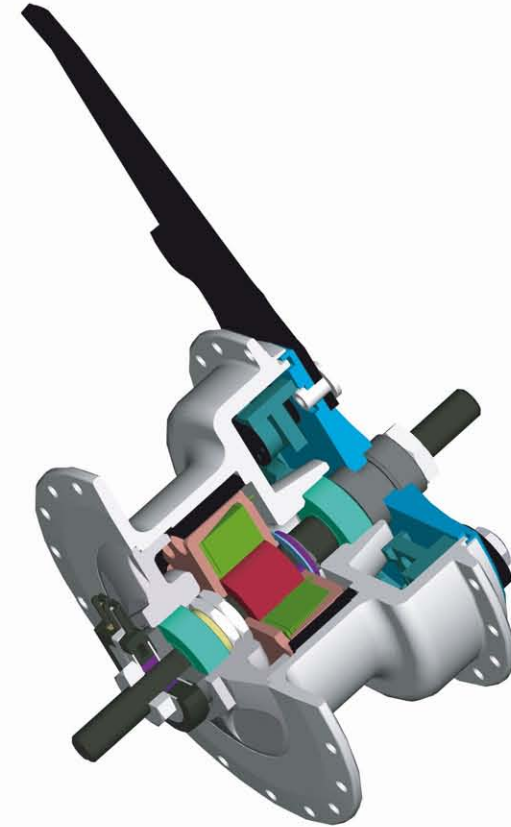
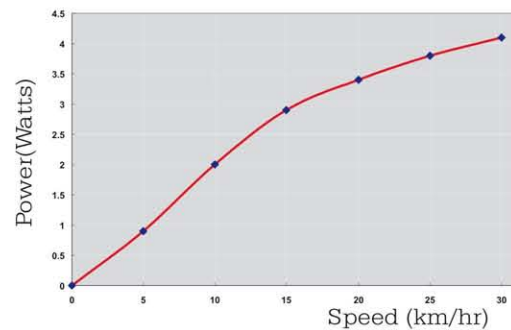
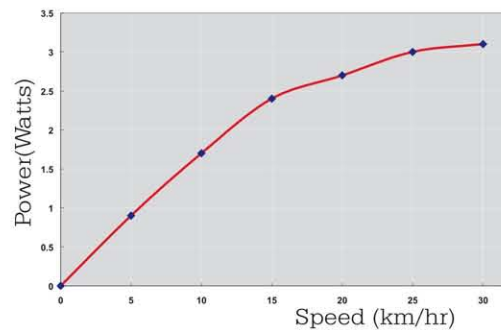
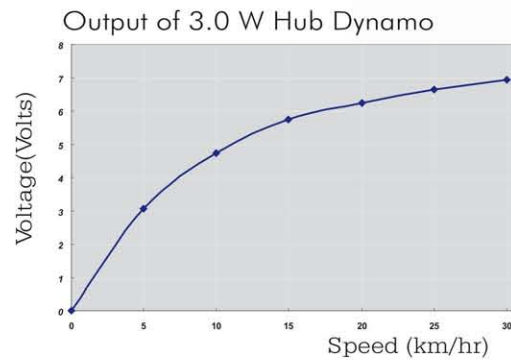
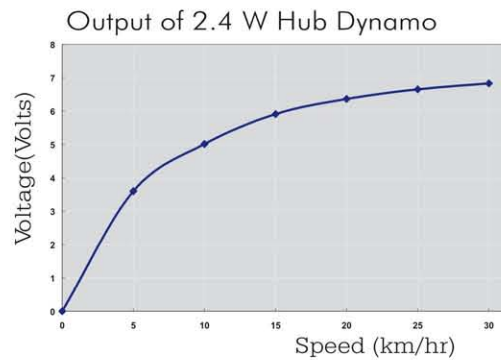



XL-FDD 6V*3.0W
HDS93T
90mm Front Drum Brake Hub
[Sealed Cartridge Bearing]



XL-FDD 6V*2.4W
HDS92T
90mm Front Drum Brake Hub
[Sealed Cartridge Bearing]



X-FDD 6V*3.0W
HDS31T
70mm Front Drum Brake Hub
[Sealed Cartridge Bearing]



X-FDD 6V*2.4W
HDS21T
70mm Front Drum Brake Hub
[Sealed Cartridge Bearing]



HMN386
3809.0205.141
HMN414 [Xylan]
3809.0212.017



HMW527
3809.0405.078



HMW528
3809.0405.081



Washer 1/16"
HMW146
3809.0405.012

- 8-speed with wide gear ratio of 325%.
- Logical gear steps of 30%, 14%, 14%, 14%, 14%, 14%, 30%.
- Patented modular technology.
- Rotary gear selector with no protrusions outside the frame.
- Quick and easy gear change with low change load.
- Direct drive in 1st gear allows use of smaller chainwheels.
- Available with integrated drum brake or use with disc brake.
- Polished aluminum hub shells.
- Twist shifter with light action and small rotating angle.
- Brake lever integrated with replaceable cartridge rubber padding.

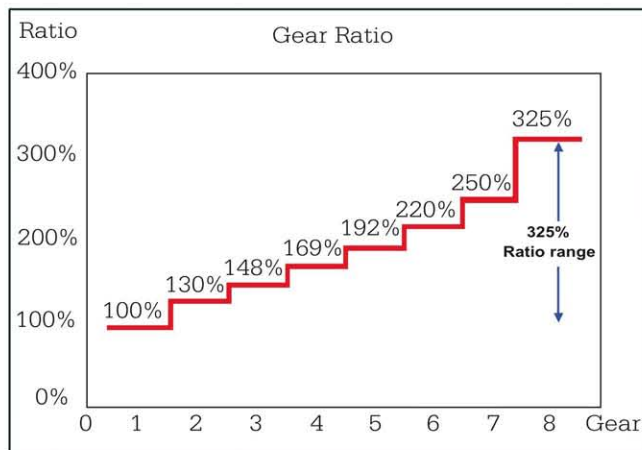
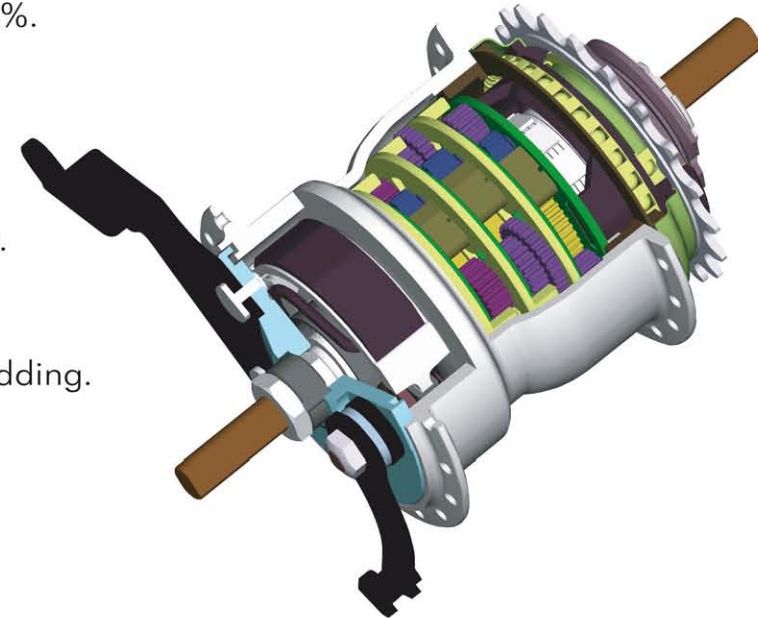

580 [W]

8 Speed Hubs



TSS86
HSJ980



CTS8X [B]



CTS8X [S]



BLS80
S [Silver]



CTS80



CTS70
[Steel Cage]



BLS80-P
Parking Brake Button
S [Silver]



X-RD8 [W]
8 Speed
70mm Drum Brake Hub



X-RK8 [W]
8 Speed
Disc Brake Hub



X-RF8 [W]
8 Speed Hub



Dust Cap
HSL882
3809.0805.032



25T CP 1/8" Dished
HSL822
CSIMW.25D



23T CP 1/8" Dished
HSL821
CSIMW.23D



20T CP 3/32" Flat
HSL897
CSIMN.20F



Sprocket Circlip
HSL880 [Xylan]
3809.0707.003

25T CP 3/32" Dished
HSL867
CSIMN.25D

23T CP 3/32" Dished
HSL868
CSIMN.23D



Rotary Cable Anchorage
HSL802
3899.0000.163



Fulcrum Lever
HSJ956
3810.0190.007



Fulcrum Lever Cilp
HSJ957
3810.0190.008



Dome Nut
HMN412 [Xylan]
3809.0212.019



Lock Washer
13/32" x 6mm x 9.7mm
HMW534 [Xylan]
3809.0410.003



Lock Washer
13/32" x 4mm x 9.5mm
HMW529 [Xylan]
3809.0407.015

Fitting Sets

HF8W8.HSSS	 HSL882	 HSJ956	 HSJ957	 HSL880	 HMN412 (x 2)	 HMW529 (x 2)
HF8W8.VSSS	 HSL882	 HSJ956	 HSJ957	 HSL880	 HMN412 (x 2)	 HMW534 (x 2)

- 5-speed with wide gear ratio of 256%.
- Gear steps of 20%, 33%, 33%, 20%.
- Disc brake hub in aluminum.
- Integrated 90mm and 70mm drum brake hub in aluminum.
- EN approved coaster brake in aluminum or steel shells.
- Thumb shifters available.
- Trigger shifter available.
- Light action twist shifter now compatible with all 5-speed.

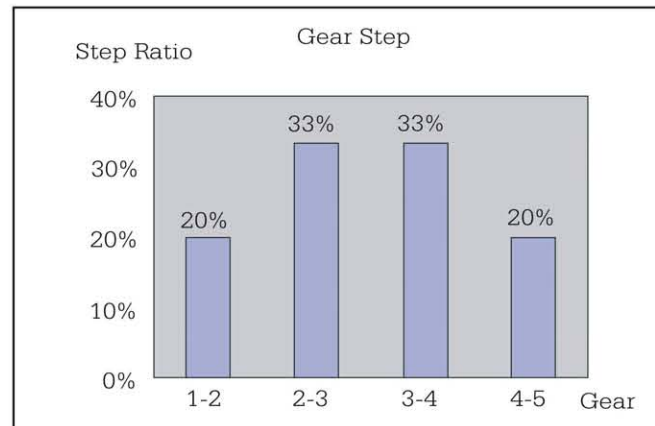
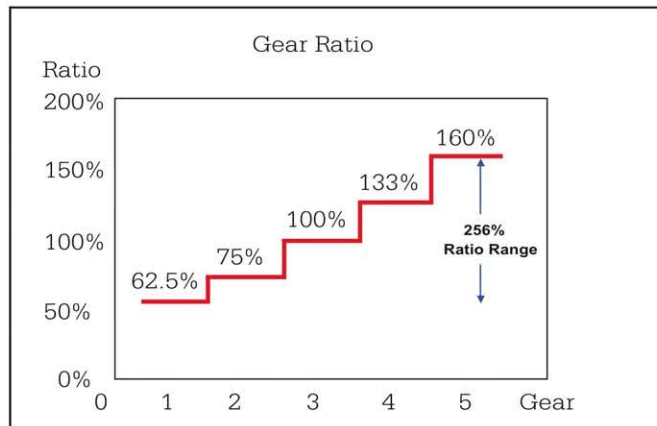
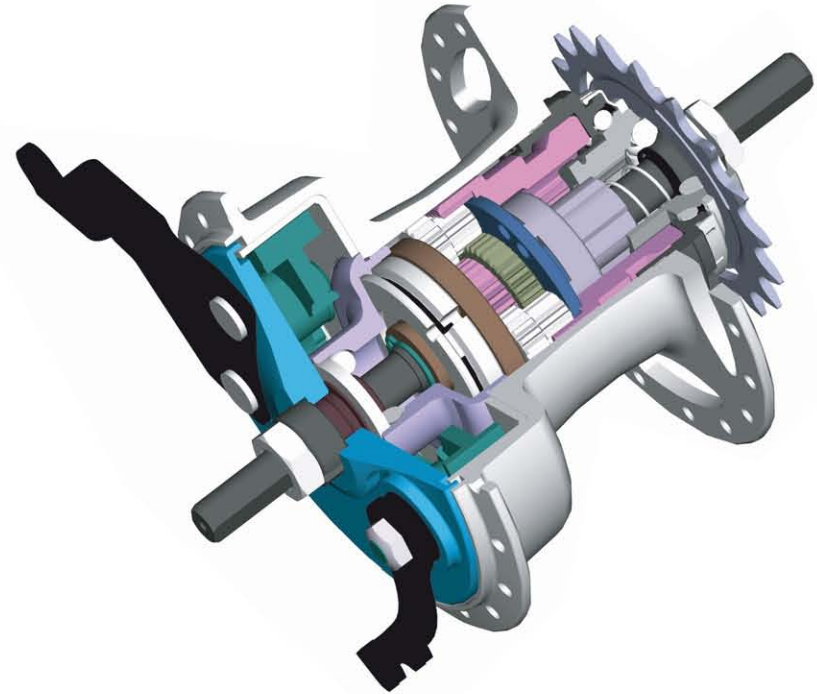



XL-RD5 [W]
5 Speed
90mm Drum Brake Hub



X-RD5 [W]
5 Speed
70mm Drum Brake Hub



X-RK5 [W] / [N]
5 Speed
Disc Brake Hub



X-RF5 [W]
5 Speed Hub



X-RC5 [W]
5 Speed
Coaster Brake Hub



S-RK5 [W] / [N]
5 Speed
Disc Brake Hub



S-RF5 [W] / [N]
5 Speed Hub



S-RC5 [W] / [N]
5 Speed
Coaster Brake Hub



S5C [W]
5 Speed
Coaster Brake Hub



DLS52
HSJ958



TSS56
HSJ979



SLS50-B
HSJ960
Bar End



SLS50-P [φ 27.2]
HSJ961
Seat Post



SLS50-S
HSJ982
Braze On 28.6mm



SLS50-T [φ 22.2] HSJ959
H [φ 31.8] HSJ994
Thumb Shifter

550 [W]

555 [W]

5 Speed Parts



Guide Nut - Short
HMN420
3809.0225.003



Guide Nut-Standard
HMN129
3809.0213.001
HMN418 [Xylan]
3809.0217.002



Gear Selector Guide
HSA650
3899.0000.384



Fulcrum Lever With Locating Washer
HSJ905
3810.0105.011



Gear Selector Guide Full Cover
HSA620
3810.0505.019



Cover for Short Guide Nut
HSL884
3810.0505.028



Cover for Short Guide Nut
HSL906 [Silver]
3810.0507.003



Lock Washer
13/32" x 4mm x 9.5mm
HMW518
3809.0405.118



Lock Washer
13/32" x 2mm x 9.5mm
HMW529 [Xylan]
HMW526
3809.0405.119



Mark Yellow
HSA585
3810.0605.026



Mark Navy Blue
HSA712
3810.0605.033



Mark Green
HSA651
3810.0605.034



Mark Purple
HSA717
3810.0605.032



Nut
HMN128
3809.0205.144
HMN411 [Xylan]
3809.0212.011



Dome Nut
HMN388
3809.0205.140
HMN412 [Xylan]
3809.0212.019



Sprocket Circlip
HSL721
3809.0705.005
HSL879 [Xylan]
3809.0707.002



Sprocket Options
(Page 42)

550 [W]**555 [W]****5 Speed Parts**

Sprocket Options (Page 42)

Fitting Sets

HFIS5.GHHA	 HSA651	 HSL721	 HMN420	 HSL884	 HMN128	 HMW526 (x 2)	
HFIS5.NHSS	 HSA712	 HSL721	 HMN420	 HSL884	 HMN388	 HMW518 (x 2)	
HFIS5.YCSS	 HSA585	 HSL721	 HMN129	 HSL711	 HMN388	 HMW518 (x 2)	
HFIS5.YSSS	 HSA585	 HSL721	 HSA650	 HMN128	 HSJ905	 HMN388	 HMW518 (x 2)
HFXS5.YSSS	 HSA585	 HSL879	 HSA650	 HMN411	 HSJ905	 HMN412	 HMW529 (x 2)
HFIS5.PHSV	 HSA717	 HSL721	 HMN420	 HSL884	 HMN388	 HMW534 (x 2)	

- 3-speed with standard gear ratio of 177%.
- Gear steps of 33% and 33%.
- Rotary gear selector with no protrusions outside the frame.
- Available as standard hub or with integrated 70mm drum brake.
- Aluminum shells.
- Twist shifter and trigger shifter option.

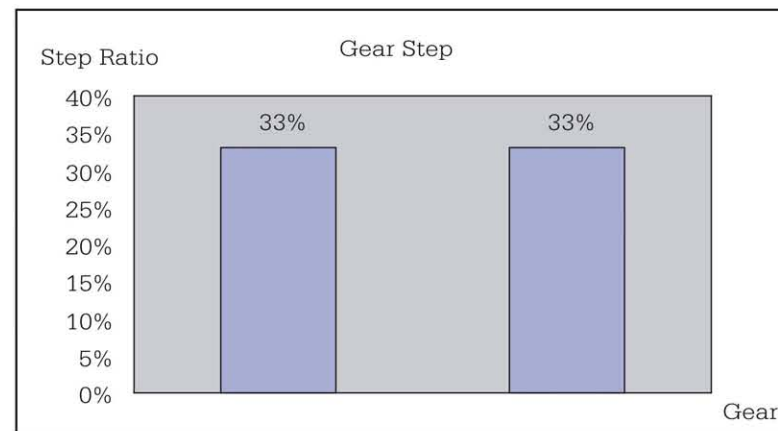
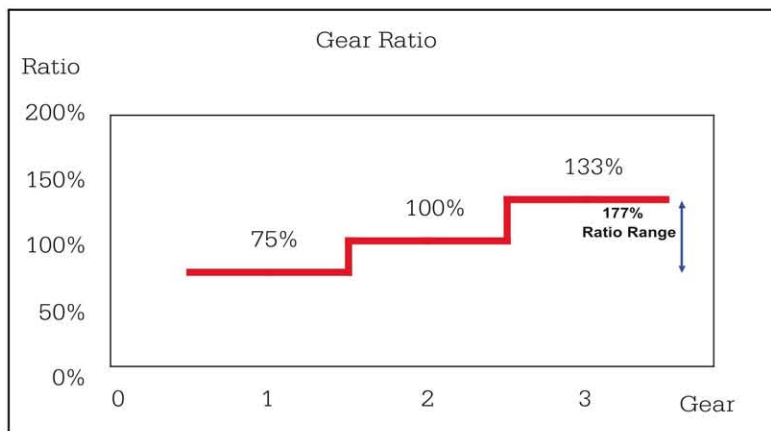
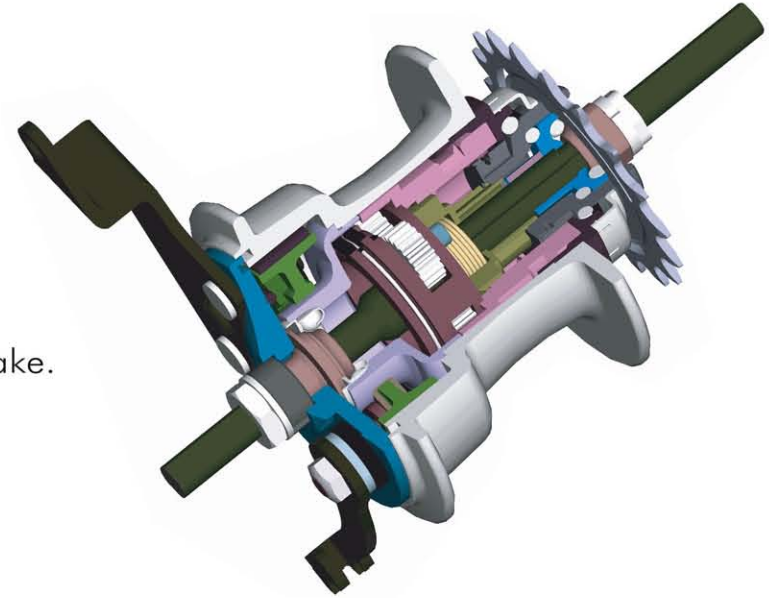



DLC34
HSJ940



TSC30
HSJ976



RX-RD3
3 Speed
70mm Drum Brake Hub



RS-RF3
3 Speed Hub



Rotary Cable Anchorage

HSL802

3899.0000.163

C30 Cable Adjuster

HSL872

3899.0000.204



C30 Fulcrum Lever Set for Reversed End

HSJ932

3899.0000.190



Tool

HTR137

3810.0590.001



Sprocket Circlip

HSL721

3809.0705.005

HSL879 [Xylan]

3809.0707.002



17T

HSL828 [Black]

HSL827 [CP]

HSL826 [Xylan]

CSISW.17P



HMN406

3809.0205.151

HMN417 [Xylan]

3809.0212.005



Lock Washer

3/8" x 4mm x 9.5mm

HMW530 [Xylan]

3809.0407.002

HMW521

3809.0405.121



HMN387

3809.0205.142

HMN413 [Xylan]

3809.0212.018

Fitting Sets



HFIC3.SSSS
HFXC3.SSSS

HSJ932
HSJ932



HMN406
HMN417



HSL721
HSL879



HMW521 (x 2)
HMW530 (x 2)



HMN387 (x 2)
HMN413 (x 2)

- Classic 3-speed with standard gear ratio of 177%.
- Gear steps of 33% and 33%.
- Disc brake hub in aluminum shell with 135mm O.L.D.
- Available as standard hub, integrated 90mm & 70mm drum brake.
- EN approved coaster brake.
- Available in aluminum or steel hub shells.
- Wide selection of gear controls including thumb, trigger, twist, stick lever, and bar end shifters.
- Aluminum thumb shifters for bar end, flat bar, or seat post mount.

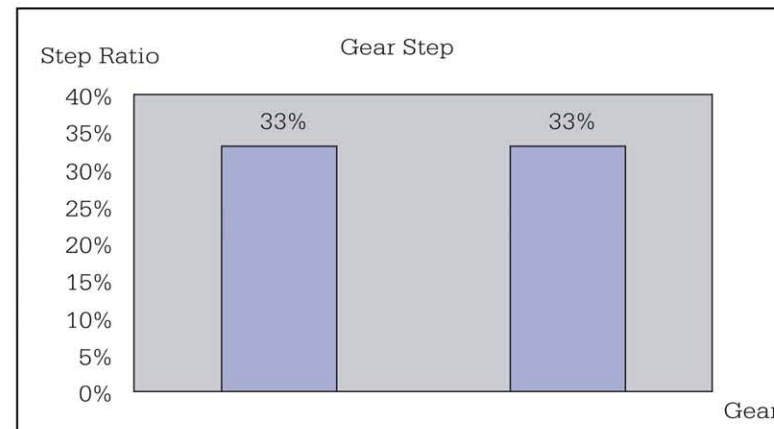
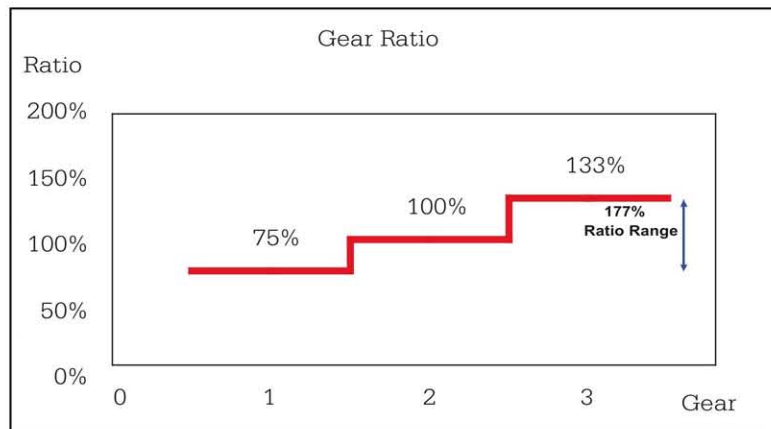
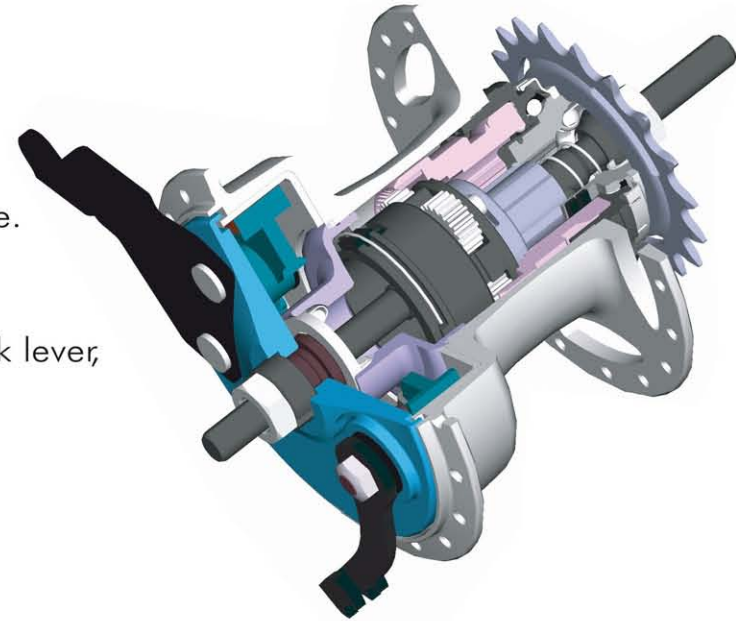

530

| 3 Speed Alloy Hubs



SLS30-B
HSJ963
Bar End Shifter



SLS30-T [φ 22.2] HSJ962
H [φ 31.8] HSJ995
Thumb Shifter



SLS30-P [φ 27.2]
HSJ993
Seat Post



SLS30-S
HSJ981
Braze On 28.6mm



DLS30
HSJ943



XL-RD3
3 Speed
90mm Drum Brake Hub



X-RD3
3 Speed
70mm Drum Brake Hub



TSS37
HSJ978



S-RK3
3 Speed
Disc Brake Hub



S-RC3 [II]
3 Speed
Coaster Brake Hub



S-RF3 / S-RF3 [N]
3 Speed Hub



TSS36
HSJ977



TSS33
HSJ939



SLS3C
HSJ762
Classic Trigger



SLS3N
HSJ823
Thumb Shifter



AB3
3 Speed
90mm Drum Brake Hub



SAB3
3 Speed
70mm Drum Brake Hub



AWC [II]
3 Speed
Coaster Brake Hub



AW
3 Speed Hub

SX | **TS** | **QS**



SX-RK3
3 Speed
Disc Brake Hub



SX-RB3
3 Speed
Band Brake Hub



TS-RC5
5 Speed
Coaster Brake Hub
Fitting Sets HFIS5.YSSS (Page 15)



TS-RC3
3 Speed
Coaster Brake Hub



TS-RF5
5 Speed Hub
Fitting Sets HFIS5.YSSS (Page 15)



TS-RF3
3 Speed Hub



TS-RB3
3 Speed
Band Brake Hub



QS-RC5
5 Speed
Reversible
Coaster Brake Hub
Fitting Sets HFIS5.YSSS (Page 15)



QS-RC3
3 Speed
Reversible
Coaster Brake Hub



CLS31
HSJ944
CLS51
HSJ984



CLS30
HSJ945
CLS50
HSJ983



CLS3S
HSJ946
CLS5S
HSJ985



CLS3M
HSJ947
CLS5M
HSJ986



Fitting Sets

HFIS3.2HHA	 HSA126	 HSL721		 HMN420	 HSL884	 HMN128	 HMW526 (x 2)
HFIS3.3CSS	 HSA315	 HSL721		 HMN129	 HSL711	 HMN388	 HMW518 (x 2)
HFIS3.3SSS	 HSA315	 HSL721	 HSA650	 HMN128	 HSJ905	 HSA620	 HMW518 (x 2)
HFIS3.3SSS	 HSA315	 HSL879	 HSA650	 HMN411	 HSJ905	 HSA620	 HMW529 (x 2)
HFIS3.4CSS	 HSA316	 HSL721		 HMN129	 HSL711	 HMN388	 HMW518 (x 2)
HFIS3.4SSS	 HSA316	 HSL721	 HSA650	 HMN128	 HSJ905	 HSA620	 HMW518 (x 2)
HFIS3.4SSS	 HSA316	 HSL879	 HSA650	 HMN411	 HSJ905	 HSA620	 HMW529 (x 2)
HFIS3.5CSS	 HSA420	 HSL721		 HMN129	 HSL711	 HMN388	 HMW518 (x 2)
HFIS3.5SSS	 HSA420	 HSL721	 HSA650	 HMN128	 HSJ905	 HSA620	 HMW518 (x 2)
HFIS3.5SSS	 HSA420	 HSL879	 HSA650	 HMN411	 HSJ905	 HSA620	 HMW529 (x 2)
HFIS3.9HSV	 HSA715	 HSL721		 HMN420	 HSL884	 HMN388	 HMW534 (x 2)

- 3-speed fixed gear with close gear ratio of 160%.
- Gear steps of 20% and 33%.
- Threaded driver compatible for non-fixed 3-speed conversion with standard single speed freewheel.
- Polished and anodized aluminum shell in option colors.
- Aluminum lock-ring and spacers achieve chain lines of 42, 43, 44, and 45mm.
- 1/8" sprocket available from 12~18T in chrome plated finish.
- 3/32" sprocket available with 12 & 13T in chrome plated finish.
- Aluminum thumb shifter for bar end, flat bar, or seat post mount.
- Matching track style chainwheels in 130mm or 144mm PCD from 42~48T.
- Matching track style front hub that is polished and anodized in option colors.

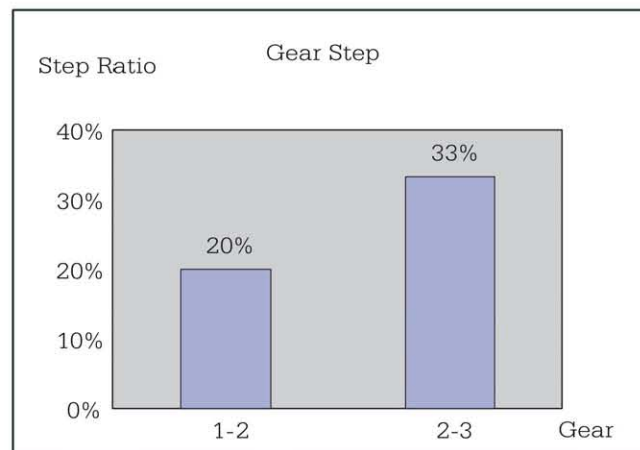
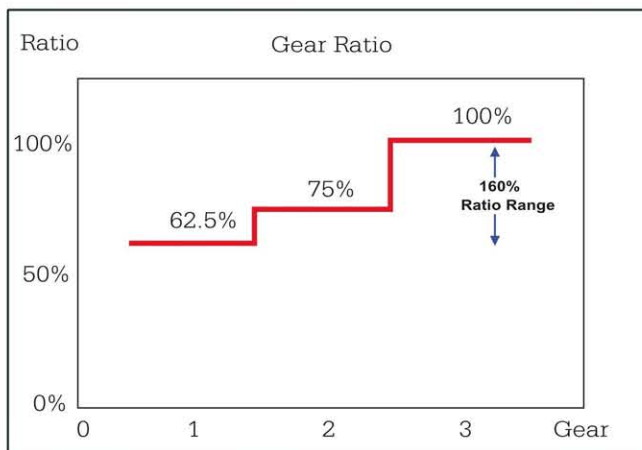
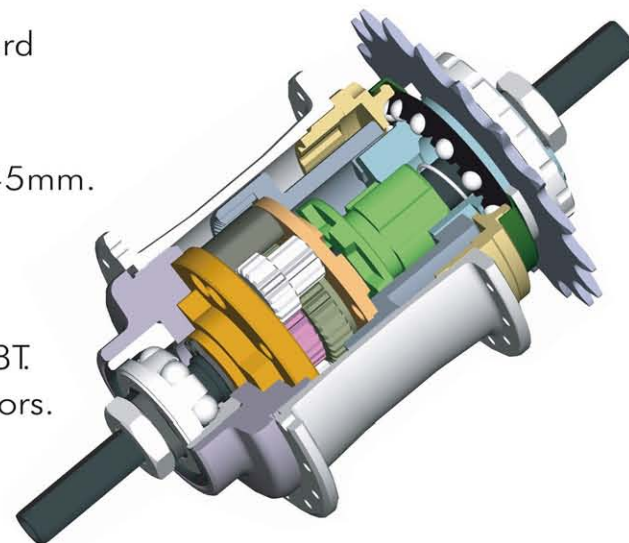



SLS3X-B
HSJ966
Bar End



SLS3X-T [∅ 22.2] HSJ965
H [∅ 31.8] HSJ990
Thumb Shifter



SLS3X-P [∅ 27.2]
HSJ991
Seat Post



SLS3X-S
HSJ988
Brazed On 28.6mm



HBT30-F
Front Hub



HBT30-R
Rear Hub



S3X
3 Speed
Fixed Gear Hub



M9
HMN426
3809.0225.004



M10
HMN427
3809.0225.007

Color Options



[B]



[G]



[R]



[2]



[3]



S3X Black [B]
3 Speed
Fixed Gear Hub



S3X Gold [G]
3 Speed
Fixed Gear Hub



S3X Red [R]
3 Speed
Fixed Gear Hub



S3X Blue [2]
3 Speed
Fixed Gear Hub



S3X Purple [3]
3 Speed
Fixed Gear Hub



CNX46 (S)
[1/2" x 1/8"]
S[Silver]

CNX58 (S)
[1/2" x 3/32"]
S[Silver]



CNX56 (S)
[Hollow Pins]
[1/2" x 1/8"]
S[Silver]

CNX59 (S)
[Hollow Pins]
[1/2" x 3/32"]
S[Silver]



FCT60 Series
(Page 36)



FCT60 Series
(Page 36)



FCT40 Series
(Page 37)



FCT20 Series
(Page 37)



FCT10 Series
(Page 37)



Mark Orange I
HSA652
3810.0605.036

Mark Orange II
HSA713
3810.0605.037

*Standard Guide Nut Only



Mark White I
HSA653
3810.0605.038

Mark White II
HSA714
3810.0605.039

*Standard Guide Nut Only



Guide Nut - Short
HMN420
3809.0225.003



Guide Nut - Standard
HMN129
3809.0213.001
HMN418 [Xylan]
3809.0217.002



Lock Washer
13/32" x 4mm x 9.5mm
HMW518
3809.0405.118
HMW529 [Xylan]
3809.0407.015



Nut
HMN128
3809.0205.144
HMN411 [Xylan]
3809.0212.011



Dome Nut
HMN388
3809.0205.140
HMN412 [Xylan]
3809.0212.019



Dust Cap
HSL701
3809.0810.001



Lock-Ring
HSL896
3809.0812.005























Sprocket Spacer
Options
(Page 43)



CSIX Sprocket
Options
(Page 43)

Fitting Sets

HFS3X.SSSS										
	HSA652	HSL701	HSL896	HMW538 (x 2)	HMW537 (x 2)	HMN420	HMN388	HMW518 (x 2)		
HFS3X.WSSS										
	HSA653	HSL701	HSL896	HMW538 (x 2)	HMW537 (x 2)	HMN420	HMN388	HMW518 (x 2)		

- 3-speed internal gear cassette freehub with gear ratio of 177%.
- Gear steps of 33% and 33%.
- Available as standard hub or disc brake hub.
- Compatible with standard MTB/ATB 9 and 8-speed cassettes.
- Compatible with standard MTB/ATB left hand shifters for front triple chainwheel.
- Compatible with standard 135mm frame dropouts.
- Polished and anodized aluminum shell in alloy silver or black.

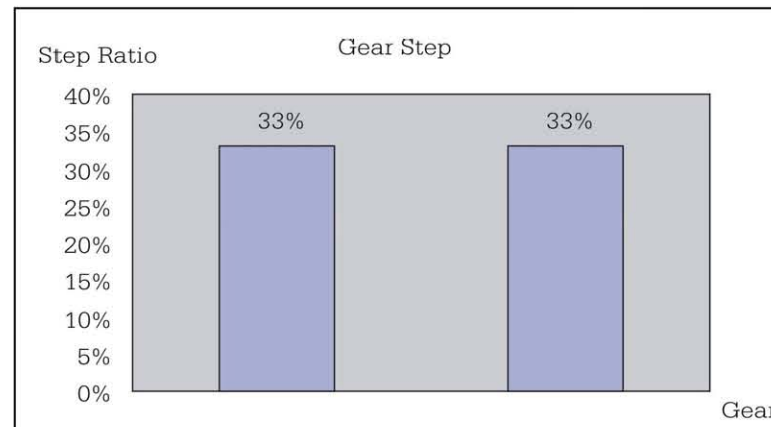
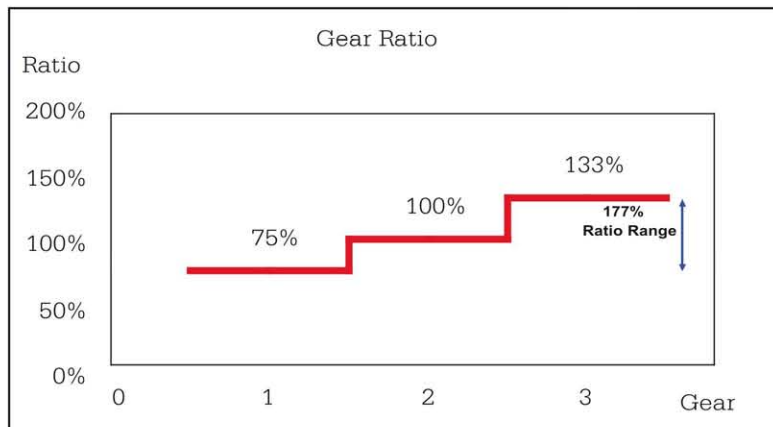
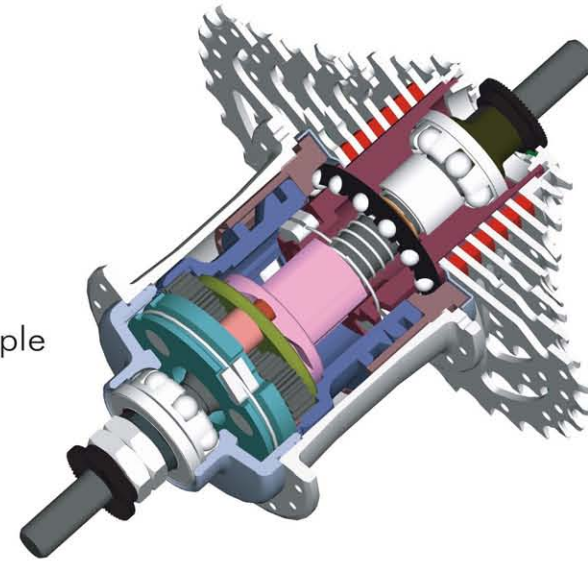



CS-RF3
3 Speed
Cassette Freehub



CS-RF3 Black [B]
3 Speed
Cassette Freehub



CS-RK3
3 Speed
Disc Brake Cassette Freehub



CS-RK3 Black [B]
3 Speed
Disc Brake Cassette Freehub

Fitting Sets



HFIF3.8SSV



HSA716



HSL922
3809.0812.008
Dust Cap



HMN420



HSL884



HMN388



HMW534 (x 2)

- 2-speed internal gear hub with gear ratio of 138%.
- Kick Shift between gears without shifters.
- No shifter cable and wear related issues.
- Available as standard hub or integrated coaster brake hub.
- Available in aluminum polished and anodized hub shell.
- Available in steel painted hub shell.

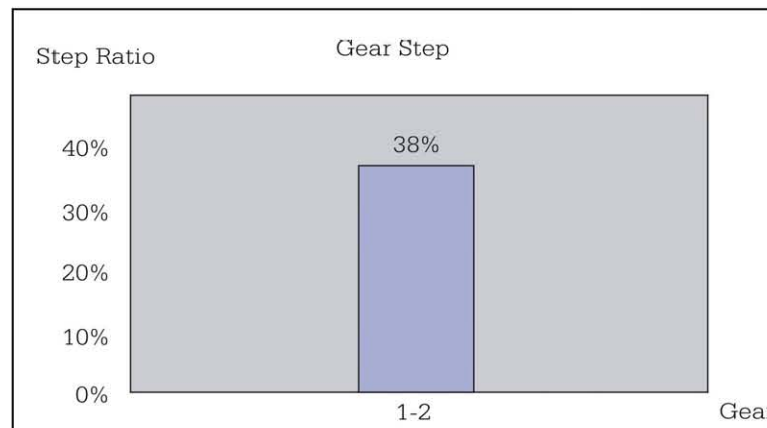
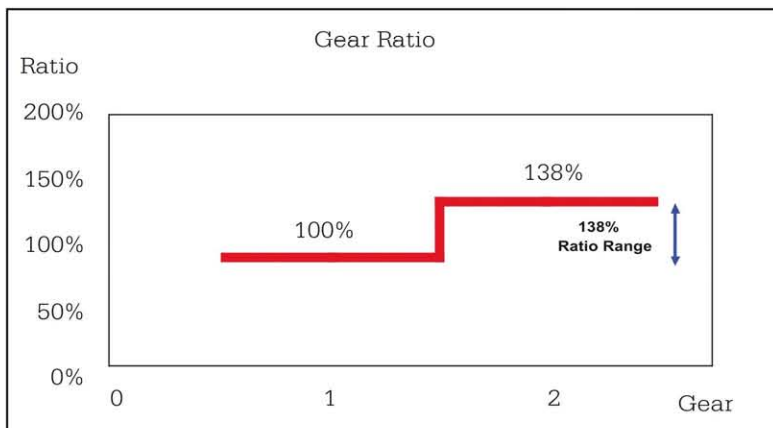
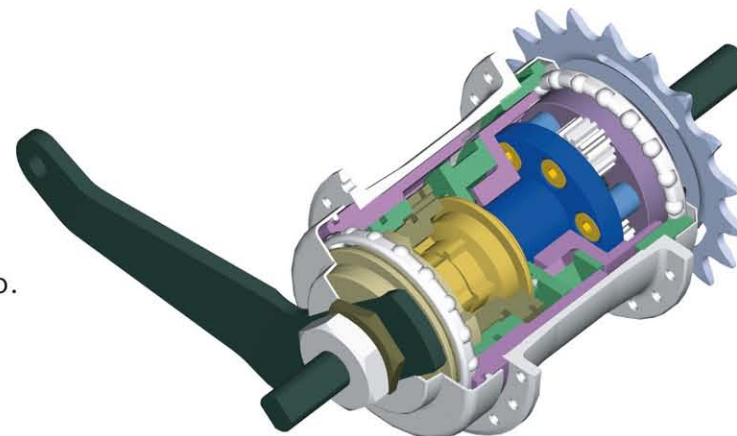

520 | 525 Kick Shift 2 Speed



S2
2 Speed Kick Shift Hub



S2C
2 Speed Kick Shift
Coaster Brake Hub

Color Options



[B]



[G]



[R]



[2]



[3]



B2C
2 Speed Kick Shift
Coaster Brake Hub

Fitting Sets

HFS20.SOSS



HSL721



HMN388 (x 2)



HMW518 (x 2)

HFS2C.SCSS



HSL721



HSL921
3809.0812.009
Dust Cap



HMW127 (x2)
3809.0405.014
Sprocket Spacer



HMN388 (x 2)



HMW518 (x 2)

Drum Brake Hubs

Front & Rear



XL-FD
90mm Front
Drum Brake Hub



X-FD
70mm Front
Drum Brake Hub



X-RDC
70mm Rear
Drum Brake for Cassettes
Q [Quick-Release]
S [Nuttet]



BF
90mm Front
Drum Brake Hub



SBF
70mm Front
Drum Brake Hub



X-RD
70mm Rear
Drum Brake for Freewheel
R[Single Speed]
7[7-Speed]

Drum Brake Hubs



XL-SD [Q]
THH90 L
90mm Left
Drum Brake Hub
Q [QR Axle Type]



XL-SD [Q]
THH90 R
90mm Right
Drum Brake Hub
Q [QR Axle Type]



XL-SD [S/C]
THH80 L
90mm Left
Drum Brake Hub
S [Solid Axle 130mm]
C [Solid Axle 100mm]
B [Solid Axle 90mm]



XL-SD [S/C]
THH80 R
90mm Right
Drum Brake Hub
S [Solid Axle 130mm]
C [Solid Axle 100mm]
B [Solid Axle 90mm]



X-SD [Q]
THH60 L
70mm Left
Drum Brake Hub
Q [QR Axle Type]



X-SD [Q]
THH60 R
70mm Right
Drum Brake Hub
Q [QR Axle Type]



X-SD [S/C]
THH50 L
70mm Left
Drum Brake Hub
S [Solid Axle 130mm]
C [Solid Axle 100mm]
B [Solid Axle 90mm]



X-SD [S/C]
THH50 R
70mm Right
Drum Brake Hub
S [Solid Axle 130mm]
C [Solid Axle 100mm]
B [Solid Axle 90mm]

Left & Right Side

XL-SD Hub Shell 36H Assy. (w/ 6001-ZZ x2)	HSB520	3899.0000.406
XL-SD Hub Shell 32H Assy. (w/ 6001-ZZ x2)	HSB541	3899.0000.502
XL-SD Hub Shell 28H Assy. (w/ 6001-ZZ x2)	HSB540	3899.0000.501

90mm Left Brake Plate Assy. (w/ QR Base)	HSB519	3899.0000.405
90mm Right Brake Plate Assy. (w/ QR Base)	HSB518	3899.0000.404
Quick Release Axle	HSL819	3809.0205.058

90mm Left Brake Plate Assy.	HSB517	3899.0000.403
90mm Right Brake Plate Assy.	HSB516	3899.0000.402
Inner Washer "A2"	HMW539	3809.0405.110
Outer Washer	HMW533	3809.0405.036
130 mm Solid Axle	HSL881	3805.0205.030
100 mm Solid Axle	HSL885	3805.0205.029
90mm Solid Axle	HSL898	3805.0205.035
M12 Nut	HMN421	3809.0205.124
M12 Nut w/ Non-Slip	HMN422	3809.0205.119

X-SD Hub Shell 36H Assy. (w/ 6001-ZZ x2)	HSB500	3899.0000.393
X-SD Hub Shell 32H Assy. (w/ 6001-ZZ x2)	HSB539	3899.0000.500
X-SD Hub Shell 28H Assy. (w/ 6001-ZZ x2)	HSB538	3899.0000.488

70mm Left Brake Plate Assy. (w/ QR Base)	HSB514	3899.0000.354
70mm Right Brake Plate Assy. (w/ QR Base)	HSB515	3899.0000.355
Quick Release Axle	HSL819	3809.0205.058

70mm Left Brake Plate Assy. "A2"	HSB530	3899.0000.307
70mm Right Brake Plate Assy. "A2"	HSB531	3899.0000.308
Inner Washer "A2"	HMW539	3809.0405.110
Outer Washer	HMW533	3809.0405.036
130 mm Solid Axle	HSL881	3805.0205.030
100 mm Solid Axle	HSL885	3805.0205.029
90mm Solid Axle	HSL898	3805.0205.035
M12 Nut	HMN421	3809.0205.124
M12 Nut w/ Non-Slip	HMN422	3809.0205.119

Front Cranksets FCS



FCSX4 34T
FCSX6 36T

BBRS [A1]
[Int. BB]
[125g]

[6061 Forged Alloy Crank]
[7075 Chainrings]
[Chromoly ISIS Axle]
[7075 Bolts & Nuts]
[7075 Axle Bolt]
[BCD 110mm]
[855~859g incl. BB]



FCS70 42T Steel w/ Steel CGs.
FCS71 42T Steel w/ Aluminum OCG and Steel ICG.
FCS72 44T Steel w/ Steel CGs.
FCS73 44T Steel w/ Aluminum OCG and Steel ICG.
FCS74 44T Aluminum w/ Aluminum OCG and Steel ICG.
[SCM435 Bolts & Nuts]
FCS7B 42T Steel w/ Aluminum OCG.
[SUS302 Bolts & Nuts]



FCSS1 54T
[Double/Chain Guard]

[Black]

FCSS2 56T
[Single Chain Guard]

[Black]
[CNC Option]

Front Cranksets FCS



FCS80 30T
FCS81 33T
[Aluminum I-Crank]
[3mm Chainring]



FCSA3 33T
FCSA6 36T
FCSA8 38T
[Aluminum A-Crank]
[2mm Chainring]

FCSB8 38T
[Aluminum A-Crank]
[3mm Chainring]



FCS50 33T
FCS51 36T
FCS52 38T
[Aluminum I-Crank]
[2mm Chainring]

FCS52
[CGs]



FCS30 33T
FCS31 36T
FCS32 38T
[Aluminum A-Crank]
[2mm Chainring]

FCS32
[CGs]

Front Cranksets FCT



AA [Alloy + Alloy]



BA
[Black + Alloy]



GA
[Gold + Alloy]



RA
[Red + Alloy]



2A
[Blue + Alloy]



3A
[Purple + Alloy]

FCT62 42T [6061 Forged Alloy Crank]
 FCT64 44T [7075 Chainring]
 FCT66 46T [7075 Bolts & Nuts]
 FCT68 48T [PCD 144mm]
 [Polished Anodized Finish Crank & Chainring]



AD [Alloy + Black]



BD
[Black + Black]



GD
[Gold + Black]



RD
[Red + Black]



2D
[Blue + Black]



3D
[Purple + Black]

FCT62 42T [6061 Forged Alloy Crank]
 FCT64 44T [7075 Chainring]
 FCT66 46T [7075 Bolts & Nuts]
 FCT68 48T [PCD 144mm]
 [Polished Anodized Finish Crank]
 [Black Anodized + CNC Chainring]

Front Cranksets FCT



AD [Alloy + Black]

- FCT42 42T [6061 Forged Alloy Crank]
- FCT44 44T [7075 Chainring]
- FCT46 46T [7075 Bolts & Nuts]
- FCT48 48T [PCD 144mm]
- [Polished Anodized Finish]
- [Black Anodized + CNC Chainring]



BD [Black + Black]



- FCT12 42T [6061 Forged Alloy Crank]
- FCT14 44T [7075 Chainring]
- FCT16 46T [SCM435 Bolts & Nuts]
- FCT18 48T [PCD 130mm]
- [Sandblast Anodized Matt Black Finish]
- [Black Anodized + CNC Chainring]



AD [Alloy + Black]

- FCT22 42T [6061 Forged Alloy Crank]
- FCT24 44T [7075 Chainring]
- FCT26 46T [SCM435 Bolts & Nuts]
- FCT28 48T [PCD 130mm]
- [Polished Anodized Finish]
- [Black Anodized + CNC Chainring]



BD [Black + Black]



- BBS18
- [Steel Axle]
 - [Alloy RH & LH Cups]
 - [Alloy Sleeve]
 - [Eng. Polymer Stopper]
 - [Sealed Cartridge Bearings]



- BBS15
- [Steel Axle]
 - [Steel RH & LH Cups]
 - [Steel Sleeve]
 - [Chrome Plated]
 - [Eng. Polymer Stopper]
 - [Sealed Cartridge Bearings]



BAS15
BB Axle Bolt
[M8]

Parts

p.44



p.45



p.39



p.39



p.43



p.43



p.45



p.46



Nuts | Washers

Front Hub



M9

Front Hub
XL-FD X-FD
XL-FDD X-FDD
HBT30-F

Rear Hub
X-RDC X-RD



Hex15

HMN386
3809.0205.141



Hex15

HMN426
3809.0225.004



HMW528
3809.0405.081



Washer 1/16"
HMW146
3809.0405.012



Washer 1/8"
HMW129
3809.0405.016

Front Hub

3/8"

BF SBF



Hex15

HMN387
3809.0205.142



Hex15

HMN118
3809.0205.150

Rear Hub

RS-RF3
RX-RD3

HMN413 [Xylan]
3809.0212.018

HMN416 [Xylan]
3809.0212.020

Rear Hub



13/32"

All Rear Hubs
[Excluding C30
Rotary Series & X-RDC]



Hex15

HMN388
3809.0205.140

HMN412 [Xylan]
3809.0212.019



Hex15

HMN128
3809.0205.144

HMN411 [Xylan]
3809.0212.011

M10
HBT30-R



Hex15

HMN427
3809.0225.007

5/3 Speed Parts

Indicators

3 Speed



Mark I
HSA125
3810.0605.019



Mark II
HSA126
3810.0605.020



Mark III
HSA315
3810.0605.021



Mark IV
HSA316
3810.0605.022



Mark V
HSA420
3810.0605.023



Mark VI
HSA615
3810.0605.024



Mark VIII
HSA716
3810.0605.040



Mark IX
HSA715
3810.0605.031

5 Speed



Mark Yellow
HSA585
3810.0605.026



Mark Green
HSA651
3810.0605.034



Mark Blue
HSA317
3810.0605.025



Mark Red
HSA490
3810.0605.027



Mark Purple
HSA717
3810.0605.032



Mark Navy Blue
HSA712
3810.0605.033

Shifter Cable/Casing Set



Twist Shifter
HSJ887 (1420mm)



SLS3N, SLS5N, SLW5N Shifter
HSJ802 (1400mm)



Orion Shifter
HSJ883 (1420mm)



Classic Trigger
HSJ102 (1420mm)
HSJ101 (530mm)

Cable Anchorage & Adjusters



HSL759
3899.0000.098



HSJ925
3899.0000.166

HSJ926
3899.0000.152 (Slotted)



HSJ542
3104.0505.018



3104.0405.002



HSJ954
3899.0000.353 (Aluminum)



5/3 Speed Parts



Guide Nut-Standard
HMN129
3809.0213.001
HMN418 [Xylan]
3809.0217.002



Guide Nut - Short
HMN420
3809.0225.003



Cover for Short Guide Nut
HSL884
3810.0505.028



HSL906 [Silver]
3810.0507.003



Indicator Guard
HSL711
3810.0505.002



Gear Selector Guide Full Cover
HSA620
3810.0505.019



Gear Selector Guide
HSA650
3899.0000.384



Fulcrum Lever
HSJ842
3810.0105.012









Fulcrum Lever with Locating Washer
HSJ905
3810.0105.011



Nut
HMN128
3809.0205.144
HMN411 [Xylan]
3809.0212.011

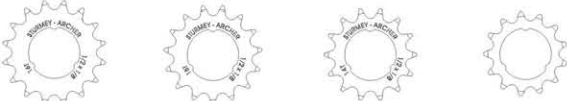

Locating Washer
HSJ929
3810.0105.008

Sprocket Teeth	22	21	20	19	18	17	16	15	14	13										
Sprocket Thickness 1/8"	<p>Deep Dished</p>  <p>Black CP Xylan</p>						 <p>CSISW.19P HSL964 [Black] HSL965 [CP] HSL966 [Xylan] CSISW.18P HSL923 [Black] HSL924 [CP] HSL925 [Xylan] CSISW.17P HSL828 [Black] HSL827 [CP] HSL826 [Xylan]</p>													
	<p>Dished</p> 																			
	<p>CSISW.22D HSL722 [Black] HSL830 [CP] HSL829 [Xylan] CSISW.21D HSL747 [Black] HSL832 [CP] HSL831 [Xylan] CSISW.20D HSL720 [Black] HSL834 [CP] HSL833 [Xylan] CSISW.19D HSL719 [Black] HSL836 [CP] HSL835 [Xylan] CSISW.18D HSL718 [Black] HSL838 [CP] HSL837 [Xylan] CSISW.17D HSL717 [Black] HSL840 [CP] HSL839 [Xylan]</p>						<p>CSISW.19F HSL781 [Black] HSL842 [CP] HSL841 [Xylan] CSISW.18F HSL818 [Black] HSL844 [CP] HSL843 [Xylan] CSISW.17F HSL772 [Black] HSL846 [CP] HSL845 [Xylan] CSISW.16F HSL716 [Black] HSL848 [CP] HSL847 [Xylan] CSISW.15F HSL715 [Black] HSL850 [CP] HSL849 [Xylan] CSISW.14F HSL714 [Black] HSL852 [CP] HSL851 [Xylan] CSISW.13F HSL713 [Black] HSL854 [CP] HSL853 [Xylan]</p>													
Sprocket Thickness 3/32"	<p>Flat</p> 																			
	<p>CSISW.22F HSL930 [Black] HSL942 [CP] HSL954 [Xylan] CSISW.21F HSL929 [Black] HSL941 [CP] HSL953 [Xylan] CSISW.20F HSL928 [Black] HSL940 [CP] HSL952 [Xylan] CSISW.19F HSL781 [Black] HSL842 [CP] HSL841 [Xylan] CSISW.18F HSL818 [Black] HSL844 [CP] HSL843 [Xylan] CSISW.17F HSL772 [Black] HSL846 [CP] HSL845 [Xylan] CSISW.16F HSL716 [Black] HSL848 [CP] HSL847 [Xylan] CSISW.15F HSL715 [Black] HSL850 [CP] HSL849 [Xylan] CSISW.14F HSL714 [Black] HSL852 [CP] HSL851 [Xylan] CSISW.13F HSL713 [Black] HSL854 [CP] HSL853 [Xylan]</p>						<p>CSISN.19D HSL776 [Black] HSL858 [CP] HSL857 [Xylan] CSISN.18D HSL775 [Black] HSL860 [CP] HSL859 [Xylan] CSISN.17D HSL774 [Black] HSL862 [CP] HSL861 [Xylan] CSISN.19F HSL936 [Black] HSL948 [CP] HSL960 [Xylan] CSISN.18F HSL935 [Black] HSL947 [CP] HSL959 [Xylan] CSISN.17F HSL934 [Black] HSL946 [CP] HSL958 [Xylan] CSISN.16F HSL773 [Black] HSL864 [CP] HSL863 [Xylan] CSISN.15F HSL933 [Black] HSL945 [CP] HSL957 [Xylan] CSISN.14F HSL932 [Black] HSL944 [CP] HSL956 [Xylan] CSISN.13F HSL931 [Black] HSL943 [CP] HSL955 [Xylan]</p>													

9-Spline Sprockets

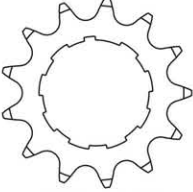
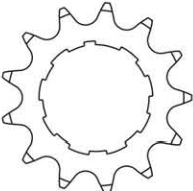
 1/8" x 1/2" Flat [CP]	13T	CSIXW.13F	HSL887
	14T	CSIXW.14F	HSL888
	15T	CSIXW.15F	HSL889
	16T	CSIXW.16F	HSL890
	17T	CSIXW.17F	HSL891
	18T	CSIXW.18F	HSL892
	19T	CSIXW.19F	HSL908
	20T	CSIXW.20F	HSL909
	21T	CSIXW.21F	HSL910
	22T	CSIXW.22F	HSL911
	 3/32" x 1/2" Flat [CP]	12T	CSIXN.12F
13T		CSIXN.13F	HSL894
14T		CSIXN.14F	HSL912
15T		CSIXN.15F	HSL913
16T		CSIXN.16F	HSL914
17T		CSIXN.17F	HSL915
18T		CSIXN.18F	HSL916
19T		CSIXN.19F	HSL917
20T		CSIXN.20F	HSL918
21T		CSIXN.21F	HSL919
22T	CSIXN.22F	HSL920	

9-Spline Spacers

Sprocket Spacer 2mm (12T Only)	HMW536	3809.0406.009
Sprocket Spacer 3mm (12T Only)	HMW535	3809.0406.010
Sprocket Spacer 2mm (13-22T)	HMW538	3809.0406.011
Sprocket Spacer 3mm (13-22T)	HMW537	3809.0406.012

Sprocket Fittings



Sprocket Circlip
 HSL721
 3809.0705.005
 HSL879 [Xylan]
 3809.0707.002



Plastic Sprocket Dustcap
 HSL871
 3809.0805.025

Lockwasher For Chain Adjuster



13/32" x 6mm x 9.7mm
 HMW534 [Xylan]
 3809.0410.003



13/32" x 4mm x 9.5mm
 HMW518
 3809.0405.118
 HMW529 [Xylan]
 3809.0407.015



13/32" x 1.8mm x 9.5mm
 HMW515
 3809.0405.120



13/32" x 2mm x 9.5mm
 HMW526
 3809.0405.119



3/8" x 4mm x 9.5mm
 HMW521
 3809.0405.121
 HMW530 [Xylan]
 3809.0407.002

Brake Cable Assembly



BSD05

[Ø1.6 Galvanized Cable+ 2P Casing]

HSK730 / BSD05.0900.BAO / 900mm

HSK764 / BSD05.0950.BAO / 950mm

HSK763 / BSD05.1000.BAO / 1000mm

HSK736 / BSD05.1600.BAO / 1600mm



BSD10

[Ø1.6 Slick Stainless Cable+ 2P Casing]

HSK747 / BSD10.0900.BAO / 900mm

HSK748 / BSD10.0950.BAO / 950mm

HSK749 / BSD10.1000.BAO / 1000mm

HSK750 / BSD10.1600.BAO / 1600mm



BSD01 [BF]

[Ø1.6 Galvanized Cable+ 2P Casing]

HSK740 / BSD01.0900.BAO / 900mm



Brake Adjuster Assembly III

HSB307

3899.0000.172

HSB537 [Xylan]

3899.0000.458

[BF]



Brake Adjuster Assembly I

HSB422

3899.0000.154

HSB536 [Xylan]

3899.0000.457

[SBF SAB3, AB3, AB5, X-FD, XL-FD, XL-FDD,
X-RD3, XL-RD3, X-RD5, XL-RD5, X-RD8]



BSD16

[Ø1.6 Slick Stainless Cable + SP Kevlar® Wrapped Casing]

HSK759 / BSD16.0900.BAO / 900mm

HSK760 / BSD16.0950.BAO / 950mm

HSK761 / BSD16.1000.BAO / 1000mm

HSK762 / BSD16.1600.BAO / 1600mm



BSD14

[Ø1.6 Slick Stainless Cable + SP Kevlar® Braided Casing]

HSK755 / BSD14.0900.BAO / 900mm

HSK756 / BSD14.0950.BAO / 950mm

HSK757 / BSD14.1000.BAO / 1000mm

HSK758 / BSD14.1600.BAO / 1600mm



BSD12

[Ø1.6 Slick Stainless Cable + SP Braided Casing]

HSK751 / BSD12.0900.BAO / 900mm

HSK752 / BSD12.0950.BAO / 950mm

HSK753 / BSD12.1000.BAO / 1000mm

HSK754 / BSD12.1600.BAO / 1600mm



Pinch Bolt

HSK715

3899.0000.124

Brake Arm Clips

Front Brake Arm Clips



17.5mm (11/16")
HSL702
3899.0000.106



22.2mm (7/8")
HSL703
3899.0000.107



Rubber Sleeve
HSL770
3810.0505.005

Rear Brake Arm Clips



15.5mm
HSL767
3899.0000.115



17.0mm (43/64")
HSL907
3899.0000.112



22.2mm (7/8")
HSL769
3899.0000.116



15.9mm (5/8")
HCB101
3899.0000.133



17.0mm (43/64")
HSL791
3899.0000.150



19.1mm (3/4")
HSL761
3899.0000.174

Fulcrum Clips & Pulleys

Fulcrum Clips



Top tube and Down tube



22.2mm (7/8")
HSJ513
3899.0000.175
include HSJ515



25.4mm (1")
HSJ512
3899.0000.100
include HSJ515



28.6mm (1-1/8")
HSJ514
3899.0000.176
include HSJ515



Fulcrum Sleeve
HSJ515
3810.0505.003

Chainstay and Backstay



15.9mm (5/8")
HSJ553
3899.0000.102



17.9mm (45/64")
HSJ548
3899.0000.101



19.1mm (3/4")
HSJ753
3899.0000.103



15.9mm (5/8")
HSJ775
3899.0000.108
include HSJ515



Pulleys

Top tube and Down tube



28.6mm (1-1/8")
HSJ521
3899.0000.105



25.4mm (1")
HSJ520
3899.0000.104



HTR140
3810.0790.002
14mm Cone Spanner



HTR141
3810.0790.003
16mm Cone Spanner



HTR142
3810.0790.004
23mm Cone Spanner



HTR145
3810.0790.008
Classic Ball Ring Spanner



HTR144
3810.0790.006
S2C Ball Ring Spanner



HTR146
3810.0790.009
S80(W) Ball Ring Spanner



HTR139
3810.0790.007
Dynohub Cap Spanner

Dynohub Drum Brakes

Model Name	XL-FDD		X-FDD	
Model No.	HDS93.TBSS.AA2	HDS92.TBSS.AA2	HDS31.TBSS.AA2	HDS21.TBSS.AA2
Model No. (High Polish)	HDS93.TBSS.HA2	HDS92.TBSS.HA2	HDS31.TBSS.HA2	HDS21.TBSS.HA2
Voltage	6V	6V	6V	6V
Output	3.0W	2.4W	3.0W	2.4W
Brake Type	90mm Drum Brake		70mm Drum Brake	
Hub Shell Material	A356 Aluminum		A356 Aluminum	
Bearing Type	Sealed Cartridge		Sealed Cartridge	
Hub Axle Diameter	9mm		9mm	
Hub Axle Length	140mm	140mm	140mm	140mm
Over Locknut Dimension	100mm	100mm	100mm	100mm
Spoke Holes	36H	36H	36H	36H
Pitch Circle Diameter	109.0mm	109.0mm	89.8mm	89.8mm
Flange Width	59.4mm	59.4mm	60mm	60mm
Center to Flange	Right	31.4mm	31.4mm	30.0mm
	Left	28.0mm	28.0mm	30.0mm
Spoke Compatibility	13G & 14G	13G & 14G	13G & 14G	13G & 14G
Finish	Natural Alloy	Natural Alloy	Natural Alloy	Natural Alloy
Weight	1,350g	1,350g	1,220g	1,220g

Brake Levers

Model Name	BLS80			
Model Number	BLS80.LNN0.SA3	BLS80.RNN0.SA3	BLS80.LNNP.SA3	BLS80.RNNP.SA3
Side	Left Hand	Right Hand	Left Hand	Right Hand
Brake Compatibility	Drum / Roller / Cantilever		Drum / Roller / Cantilever	
Parking Brake Lock Pin	✕		●	
Lever Length	4-Finger		4-Finger	
Lever Material	Aluminum		Aluminum	
Lever Comfort Pad	Replaceable Rubber Cartridge BLP80		Replaceable Rubber Cartridge BLP80	
Bracket Material	Aluminum		Aluminum	
Cable Adjuster	Anodized Aluminum		Anodized Aluminum	
Reach Adjuster	Dacromet Chromoly		Dacromet Chromoly	
Bracket Bolt	Dacromet Chromoly		Dacromet Chromoly	
Clamp Bolt	Dacromet Chromoly		Dacromet Chromoly	
Clamp Diameter	22.2mm		22.2mm	
Finish	(S) Painted Silver		(S) Painted Silver	
Average Weight	125g	125g	130g	130g

Shifters 8-Speed Twist

Model No.	TSS86 R8 (S)	TSS86 R8 (A~U)
Sales No.	HSJ980	n/a
Type	Twist	
Speeds	8-Speed Wide Ratio (W)	
Cable Adjuster	●	
Clamp Material	A6061 Aluminum	
Clamp Fastening Screw	SUS302 Stainless Steel	
Triangular Cover Screw	SCM435 Chromoly	
Cable Type	Slick-Stainless	
Cable Length	1,900mm	×
OEM Pre-Assembled	×	●
Pre-Assembled Cable Adjuster	×	●
Pre-Assembled Indicator Connector	×	●
Pre-Assembled Casing Length	×	1,200~2,000mm
Pre-Assembly Casing Type	×	SP
Weight	89g	n/a

Shifters 5-Speed Trigger

Model No.	DLS52 R5 (S)	DLS52 R5 (A~U)
Sales No.	HSJ958	n/a
Type	Dual Lever Trigger	
Speeds	5-Speed Wide Ratio (W)	
Cable Adjuster	●	
Clamp Fastening Screw	SCM435 Chromoly	
Large Lever	Aluminum	
Small Lever	Engineering Polymers	
Cable Type	Slick-Galvanized	
Cable Length	2,050mm	×
OEM Pre-Assembled	×	●
Pre-Assembled Cable Adjuster	×	●
Pre-Assembled Indicator Connector	×	●
Pre-Assembled Casing Length	×	1,200~2,000mm
Pre-Assembly Casing Type	×	SP
Weight	156g	n/a

Shifters 5-Speed Twist

Model No.	TSS56 R5 (S)	TSS56 R5 (A~U)
Sales No.	HSJ979	n/a
Type	Twist	
Speeds	5-Speed Wide Ratio (W)	
Cable Adjuster	●	
Clamp Material	A6061 Aluminum	
Clamp Fastening Screw	SCM435 Chromoly	
Triangular Cover Screw	SCM435 Chromoly	
Cable Type	Slick-Galvanized	
Cable Length	1,900mm	×
OEM Pre-Assembled	×	●
Pre-Assembled Cable Adjuster	×	●
Pre-Assembled Indicator Connector	×	●
Pre-Assembled Casing Length	×	1,200~2,000mm
Pre-Assembly Casing Type	×	SP
Weight	89g	n/a

Shifters 5-Speed Thumb

Model No.	SLS50 T5 (S)	SLS50 T5 (A~U)	SLS50 H5 (S)	SLS50 H5 (A~U)	SLS50 P5 (S)	SLS50 B5 (S)	SLS50 S5 (S)
Sales No.	HSJ959	n/a	HSJ994	n/a	HSJ961	HSJ960	HSJ982
Type	(T) Thumbie 22.2mm Clamp		(H) 31.8mm Clamp		(P) 27.2mm	(B) Bar End	(S) 28.6mm Brazed
Speeds	5-Speed Wide Ratio (W)						
Cable Adjuster	×		×		×	×	×
Lever Position Adjust	●		●		●	×	×
Lever Material	High Polished Aluminum						
Clamp Material	Aluminum		Aluminum		Aluminum	×	×
Body Material	×		×		×	●	×
Clamp Fastening Screw	SCM435 Chromoly		SCM435 Chromoly		SCM435 Chromoly	×	×
Cable Type	Slick-Galvanized						
Cable Length	1,950mm	×	1,950mm	×	1,450mm	2,400mm	1,950mm
OEM Pre-Assembled	×	●	×	●	×	×	×
Pre-Assembled Cable Adjuster	×	●	×	●	×	×	×
Pre-Assembled Indicator Connector	×	●	×	●	×	×	×
Pre-Assembled Casing Length	×	1,200~2,000mm	×	1,200~2,000mm	×	×	×
Pre-Assembly Casing Type	×	SP	×	SP	×	×	×
Weight	87g	n/a	93g	n/a	100g	105g	51g

Shifters C30 Rotary 3-Speed Trigger

Model No.	DLC34 R3 (S)	DLC34 R3 (A~U)
Sales No.	HSJ940	n/a
Type	Dual Lever Trigger	
Speeds	3-Speed (C30 Rotary Only)	
Cable Adjuster	●	
Clamp Fastening Screw	SCM435 Chromoly	
Large Lever	Aluminum	
Small Lever	Engineering Polymers	
Cable Type	Slick-Galvanized	
Cable Length	2,050mm	×
OEM Pre-Assembled	×	●
Pre-Assembled Cable Adjuster	×	●
Pre-Assembled Indicator Connector	×	●
Pre-Assembled Casing Length	×	1,200~2,000mm
Pre-Assembly Casing Type	×	2SP
Weight	156g	n/a

Shifters C30 Rotary 3-Speed Twist

Model No.	TSC30 R3 (S)	TSC30 R3 (A~U)
Sales No.	HSJ976	n/a
Type	Twist	
Speeds	3-Speed (C30 Rotary Only)	
Cable Adjuster	×	
Clamp Material	A6061 Aluminum	
Clamp Fastening Screw	SCM435 Chromoly	
Triangular Cover Screw	SCM435 Chromoly	
Cable Type	Slick-Galvanized	
Cable Length	1,900mm	×
OEM Pre-Assembled	×	●
Pre-Assembled Cable Adjuster	×	●
Pre-Assembled Indicator Connector	×	●
Pre-Assembled Casing Length	×	1,200~2,000mm
Pre-Assembly Casing Type	×	2SP
Weight	80g	n/a

Shifters 3-Speed Trigger

Model No.	DLS30 R3 (S)	DLS30 R3 (A~U)
Sales No.	HSJ943	n/a
Type	Dual Lever Trigger	
Speeds	3-Speed	
Cable Adjuster	●	
Clamp Fastening Screw	SCM435 Chromoly	
Large Lever	Aluminum	
Small Lever	Engineering Polymers	
Cable Type	Slick-Galvanized	
Cable Length	2,050mm	×
OEM Pre-Assembled	×	●
Pre-Assembled Cable Adjuster	×	●
Pre-Assembled Indicator Connector	×	●
Pre-Assembled Casing Length	×	1,200~2,000mm
Pre-Assembly Casing Type	×	2SP
Weight	156g	n/a

Shifters 3-Speed Twist

Model No.	TSS37 R3 (S)	TSS37 R3 (A~U)	TSS36 R3 (S)	TSS36 R3 (A~U)	TSS33 R3 (S)	TSS33 R3 (A~U)
Sales No.	HSJ978	n/a	HSJ977	n/a	HSJ939	n/a
Type	Twist		Twist		Twist	
Speeds	3-Speed		3-Speed		3-Speed	
Cable Adjuster	×		×		×	
Clamp Material	A6061 Aluminum		A6061 Aluminum		A6061 Aluminum	
Clamp Fastening Screw	SCM435 Chromoly		SCM435 Chromoly		SCM435 Chromoly	
Triangular Cover Screw	SCM435 Chromoly		SCM435 Chromoly		SCM435 Chromoly	
Cable Type	Galvanized		Galvanized		Galvanized	
Cable Length	1,900mm	×	1,950mm	×	1,950mm	×
OEM Pre-Assembled	×	●	×	●	×	●
Pre-Assembled Cable Adjuster	×	●	×	●	×	●
Pre-Assembled Indicator Connector	×	●	×	●	×	●
Pre-Assembled Casing Length	×	1,200~2,000mm	×	1,200~2,000mm	×	1,200~2,000mm
Pre-Assembly Casing Type	×	2SP	×	2SP	×	2SP
Weight	80g	n/a	62g	n/a	62g	n/a

Shifters 3-Speed Thumb

Model No.	SLS30 T3 (S)	SLS30 T3 (A~U)	SLS30 H3 (S)	SLS30 H3 (A~U)	SLS30 P3 (S)	SLS30 B3 (S)	SLS30 S3 (S)
Sales No.	HSJ962	n/a	HSJ995	n/a	HSJ993	HSJ963	HSJ981
Type	(T) Thumbie 22.2mm Clamp		(H) 31.8mm Clamp		(P) 27.2mm	(B) Bar End	(S) 28.6mm Brazed
Speeds	3-Speed						
Cable Adjuster	×		×		×	×	×
Lever Position Adjust	●		●		●	×	×
Lever Material	High Polished Aluminum						
Clamp Material	Aluminum		Aluminum		Aluminum	×	×
Body Material	×		×		×	●	×
Clamp Fastening Screw	SCM435 Chromoly		SCM435 Chromoly		SCM435 Chromoly	×	×
Cable Type	Slick-Galvanized						
Cable Length	1,950mm	×	1,950mm	×	1,450mm	2,400mm	1,950mm
OEM Pre-Assembled	×	●	×	●	×	×	×
Pre-Assembled Cable Adjuster	×	●	×	●	×	×	×
Pre-Assembled Indicator Connector	×	●	×	●	×	×	×
Pre-Assembled Casing Length	×	1,200~2000mm	×	1,200~2000mm	×	×	×
Pre-Assembly Casing Type	×	2SP	×	2SP	×	×	×
Weight	87g	n/a	93g	n/a	100g	105g	51g

Shifters 3-Speed Thumb

Model No.	SLS3C R3 (N)	SLS3C R3 (A~U)	SLS3N R3 (N)	SLS3N R3 (A~U)
Sales No.	HSJ762	n/a	HSJ823	n/a
Type	Classic Trigger		Thumb	
Speeds	3-Speed		3-Speed	
Cable Adjuster	×		×	
Lever Position Adjust	×		●	
Lever Material	Composite Covered Steel		Engineering Polymers	
Clamp Material	Steel		Steel	
Clamp Fastening Screw	Chromoly		Chromoly	
Cable Type	Slick-Galvanized		Slick-Galvanized	
Cable Length	Sold Separately	×	Sold Separately	×
OEM Pre-Assembled	×	●	×	●
Pre-Assembled Cable Adjuster	×	●	×	●
Pre-Assembled Indicator Connector	×	●	×	●
Pre-Assembled Casing Length	×	1,200~2000mm	×	1,200~2,000mm
Pre-Assembly Casing Type	×	2SP	×	2SP
Weight	68g	n/a	54g	n/a

Shifters 5 & 3-Speed Chopper Lever

Model No.	CLS51 R5	CLS50 R5	CLS5S R5	CLS5M R5	CLS31 R3	CLS30 R3	CLS3S R3	CLS3M R3
Sales No.	HSJ984	HSJ983	HSJ985	HSJ986	HSJ944	HSJ945	HSJ946	HSJ947
Type	Stick Arm Lever		Stick Arm Lever		Stick Arm Lever		Stick Arm Lever	
Speeds	5-Speed		5-Speed		3-Speed		3-Speed	
Lever Arm Material	Aluminum		Steel	Steel	Aluminum		Steel	Steel
Lever Arm Thickness	6mm		6mm	4mm	6mm		6mm	4mm
Lever Arm Shape	Curved		Curved	Straight	Curved		Curved	Straight
Light Weight Holes	●	×	×	●	●	×	×	●
Arm Finish	Anodized		Satin	Chrome	Anodized		Satin	Chrome
Cable Type	Sold Separately		Sold Separately		Sold Separately		Sold Separately	
Weight	377g	397.5g	658g	469g	377g	397.5g	658g	469g

Shifters S3X Fixed 3-Speed

Model No.	SLS3X T3 (S)	SLS3X T3 (A~U)	SLS3X H3 (S)	SLS3X H3 (A~U)	SLS3X P3 (S)	SLS3X B3 (S)	SLS3X S3 (S)
Sales No.	HSJ965	n/a	HSJ990	n/a	HSJ991	HSJ966	HSJ988
Type	(T) Thumbie 22.2mm Clamp		(H) 31.8mm Clamp		(P) 27.2mm	(B) Bar End	(S) 28.6mm Brazed
Speeds	3-Speed (S3X Fixed Only)						
Cable Adjuster	×		×		×	×	×
Lever Position Adjust	●		●		●	×	×
Lever Material	High Polished Aluminum						
Clamp Material	Aluminum		Aluminum		Aluminum	×	×
Body Material	×		×		×	●	×
Clamp Fastening Screw	SCM435 Chromoly		SCM435 Chromoly		SCM435 Chromoly	×	×
Cable Type	Slick-Stainless						
Cable Length	1,950mm	×	1,950mm	×	1,450mm	2,400mm	1,950mm
OEM Pre-Assembled	×	●	×	●	×	×	×
Pre-Assembled Cable Adjuster	×	●	×	●	×	×	×
Pre-Assembled Indicator Connector	×	●	×	●	×	×	×
Pre-Assembled Casing Length	×	1,200~2,000mm	×	1,200~2,000mm	×	×	×
Pre-Assembly Casing Type	×	SP	×	SP	×	×	×
Weight	87g	n/a	93g	n/a	100g	105g	51g

Internal Gear Hubs S80 (W)

Model Name		X-RD8 (W)	X-RK8 (W)		X-RF8 (W)	
Model No. (36H)		IHW8T.XBSS.HA1	IHW8K.XBLS.HA1	IHW8K.XBSS.HA1	IHW8F.XBLS.HA1	IHW8F.XBSS.HA1
Model No. (32H)		IHW8T.XCSS.HA1	IHW8K.XCLS.HA1	IHW8K.XCSS.HA1	IHW8F.XCLS.HA1	IHW8F.XCSS.HA1
Model No. (28H)		×	×	×	×	IHW8F.XDSS.HA1
Speed		8-Speed	8-Speed		8-Speed	
Type		70mm Drum Brake	Disc Brake		Freewheel	
Hub Shell Material		A356 Aluminum	6061 Aluminum		6061 Aluminum	
Gear Ratio	Overall Range	325%				
	1	100% Direct Drive				
	2	130% [Gear 1 (+) 30%]				
	3	148% [Gear 2 (+) 14%]				
	4	169% [Gear 3 (+) 14%]				
	5	192% [Gear 4 (+) 14%]				
	6	220% [Gear 5 (+) 14%]				
	7	250% [Gear 6 (+) 14%]				
8	325% [Gear 7 (+) 30%]					
Axle Diameter		13/32" Slotted				
Axle Length		185mm	185mm	175mm	185mm	175mm
Over Locknut Dimension		132mm	134mm	128mm	135mm	120mm
R: Axle Protrusion Length		27mm	25mm	26mm	27mm	27mm
L: Axle Protrusion Length		26mm	26mm	21mm	23mm	28mm
Spoke Holes		(B) 36H / (C) 32H	(B) 36H / (C) 32H		(B) 36H / (C) 32H / (D) 28H	
Pitch Circle Diameter		89.8mm	89.8mm	89.8mm	89.8mm	89.8mm
Center to Flange	Right	32.3mm	31.2mm	29.9mm	33.3mm	26.1mm
	Left	45.7mm	27.3mm	28.6mm	25.2mm	32.4mm
Flange Width		78.0mm	58.5mm	58.5mm	58.5mm	58.5mm
Spoke Compatibility		13G & 14G	13G & 14G	13G & 14G	13G & 14G	13G & 14G
Sprocket Teeth		20, 23, 25T	20, 23, 25T	20, 23, 25T	20, 23, 25T	20, 23, 25T
Chain Line : 1/8" Dished		42.2mm	41.0mm	39.8mm	43.1mm	35.9mm
Chain Line : 3/32" Flat		46.0mm	44.9mm	43.6mm	46.9mm	39.7mm
Chain Line : 3/32" Dished		42.4mm	45.1mm	40.0mm	43.4mm	36.2mm
Finish		High Polish Alloy	High Polish Alloy	High Polish Alloy	High Polish Alloy	High Polish Alloy
Weight		2,170g	1,880g	1,860g	1,790g	1,770g

Internal Gear Hubs S50 (W)

Model Name		XL-RD5 (W)	X-RD5 (W)	X-RK5 (W)	S-RK5 (W)	X-RK5 (N)	S-RK5 (N)
Model No.		IHW5T.YBSS.AA1	IHW5T.XBSS.AA1	IHW5K.XBLS.AA1	IHW5K.QBLS.AA1	IHN5K.XBLS.AA1	IHN5K.QBLS.AA1
Model No. (High Polish)		IHW5T.YBSS.HA1	IHW5T.XBSS.HA1	×	×	×	×
Speed		5-Speed		5-Speed		5-Speed	
Type		90mm Drum Brake	70mm Drum Brake	Disc Brake		Disc Brake	
Hub Shell Material		A356 Aluminum	A356 Aluminum	6061 Aluminum	6061 Aluminum	6061 Aluminum	6061 Aluminum
Gear Ratio	Overall Range	256%		256%		256%	
	1	62.5%	(-) 37.5%	62.5%	(-) 37.5%	62.5%	(-) 37.5%
	2	75%	(-) 25% [Gear 1 (+) 20%]	75%	(-) 25% [Gear 1 (+) 20%]	75%	(-) 25% [Gear 1 (+) 20%]
	3	100%	Direct Drive [Gear 2 (+) 33%]	100%	Direct Drive [Gear 2 (+) 33%]	100%	Direct Drive [Gear 2 (+) 33%]
	4	133.3%	(+)33.3% [Gear 3 (+) 33%]	133.3%	(+)33.3% [Gear 3 (+) 33%]	133.3%	(+)33.3% [Gear 3 (+) 33%]
5	160%	(+)60% [Gear 4 (+) 20%]	160%	(+)60% [Gear 4 (+) 20%]	160%	(+)60% [Gear 4 (+) 20%]	
Axle Diameter		13/32" Slotted		13/32" Slotted		13/32" Slotted	
Axle Length		175mm	175mm	185mm	185mm	185mm	185mm
Over Locknut Dimension		130mm	130mm	135mm	135mm	135mm	135mm
R: Axle Protrusion Length		24mm	24mm	24mm	24mm	24mm	24mm
L: Axle Protrusion Length		21mm	21mm	26mm	26mm	26mm	26mm
Spoke Holes		36H	36H	36H	36H	36H	36H
Pitch Circle Diameter		109.0mm	89.8mm	89.4mm	67.0mm	89.4mm	67.0mm
Flange Width		75.7mm	77.4mm	61.4mm	56.6mm	61.4mm	56.6mm
Center to Flange	Right	31.9mm	33.0mm	36.7mm	27.8mm	36.7mm	27.8mm
	Left	43.8mm	44.4mm	24.7mm	28.8mm	24.7mm	28.8mm
Spoke Compatibility		13G & 14G	13G & 14G	13G & 14G	13G & 14G	13G & 14G	13G & 14G
Sprocket Teeth		13~22T	13~22T	13~22T	13~22T	12~22T	12~22T
Chain Line: 1/8" Flat		50.9mm	50.9mm	45.6mm	45.6mm	45.6, 48.6mm	45.6, 48.6mm
Chain Line: 1/8" Dished		49.3, 52.7mm	49.3, 52.7mm	44.0, 48.4mm	44.0, 48.4mm	×	×
Chain Line: 3/32" Flat		50.6, 51.2mm	50.6, 51.2mm	45.3, 45.9mm	45.3, 45.9mm	45.9, 48.9mm	45.9, 48.9mm
Chain Line: 3/32" Dished		48.8, 53.0mm	48.8, 53.0mm	43.5, 48.7mm	43.5, 48.7mm	×	×
Indicator Type		Yellow / Navy Blue*	Yellow / Navy Blue*	Purple	Purple	Purple	Purple
Finish		Natural Alloy	Natural Alloy	Anodized Alloy	Anodized Alloy	Anodized Alloy	Anodized Alloy
Weight		1,760g	1,570g	1,280g	1,165g	1,275g	1,160g

*Navy Blue Indicator must be used when using HMN420 Short Guide Nut.

Internal Gear Hubs S50 (W)

Model Name		X-RF5 (W)			S-RF5 (W)		S-RF5 (N)	
Model No.		IHW5F.XBSL.AA1	IHW5F.XBSS.AA1	IHW5F.QBSS.AA0	IHW5F.QDCS.AA0	IHN5F.QDCS.AA0		
Model No. (High Polish)		×	×	×	×	×		
Speed		5-Speed			5-Speed			
Type		Freewheel			Freewheel			
Hub Shell Material		6061 Aluminum			6061 Aluminum			
Gear Ratio	Overall Range	256%			256%			
	1	62.5%	(-) 37.5%		62.5%	(-) 37.5%		
	2	75%	(-) 25%	[Gear 1 (+) 20%]	75%	(-) 25%	[Gear 1 (+) 20%]	
	3	100%	Direct Drive	[Gear 2 (+) 33%]	100%	Direct Drive	[Gear 2 (+) 33%]	
	4	133.3%	(+)33.3%	[Gear 3 (+) 33%]	133.3%	(+)33.3%	[Gear 3 (+) 33%]	
	5	160%	(+)60%	[Gear 4 (+) 20%]	160%	(+)60%	[Gear 4 (+) 20%]	
Axle Diameter		13/32" Slotted			13/32" Slotted			
Axle Length		175mm	175mm	175mm	148mm	148mm		
Over Locknut Dimension		130mm	119mm	119mm	111mm	111mm		
R: Axle Protrusion Length		24mm	24mm	24mm	19mm	19mm		
L: Axle Protrusion Length		21mm	32mm	32mm	18mm	18mm		
Spoke Holes		36H	36H	36H	28H	28H		
Pitch Circle Diameter		89.4mm	89.4mm	67.0mm	67.0mm	67.0mm		
Flange Width		62.0mm	62.0mm	56.6mm	56.6mm	56.6mm		
Center to Flange	Right	36.9mm	31.4mm	27.6mm	23.8mm	23.8mm		
	Left	25.1mm	30.6mm	29.0mm	32.8mm	32.8mm		
Spoke Compatibility		13G &14G	13G & 14G	13G & 14G	13G & 14G	13G & 14G		
Sprocket Teeth		13~22T	13~22T	13~22T	13~22T	12~22T		
Chain Line: 1/8" Flat		51.1mm	45.6mm	45.6mm	41.6mm	41.6, 44.6mm		
Chain Line: 1/8" Dished		49.5 , 52.9mm	44.0 , 47.4mm	44.0 , 47.4mm	39.9 , 43.3mm	×		
Chain Line: 3/32" Flat		50.8 , 51.4mm	45.3 , 45.9mm	45.3 , 45.9mm	41.3 , 41.9mm	41.9, 44.9mm		
Chain Line: 3/32" Dished		49.0 , 53.2mm	43.5 , 47.7mm	43.5 , 47.7mm	39.5 , 43.7mm	×		
Indicator Type		Yellow / Navy Blue*	Yellow / Navy Blue*	Yellow / Navy Blue*	Green	Green		
Finish		Anodized Alloy	Anodized Alloy	Anodized Alloy	Anodized Alloy	Anodized Alloy		
Weight		1,230g	1,220g	1,090g	1,060g	1,055g		

*Navy Blue Indicator must be used when using HMN420 Short Guide Nut.

Internal Gear Hubs S50 / S5S (W)

Model Name	X-RC5 (W)	S-RC5 (W)	S-RC5 (N)	S5C (W)	
Model No.	IHW5C.XBSS.AA0	IHW5C.QBSS.AA0	IHN5C.QBSS.AA0	IHW5C.WBSS.AA0	
Model No. (High Polish)	×	×	×	×	
Speed	5-Speed	5-Speed	5-Speed	5-Speed	
Type	Coaster Brake	Coaster Brake	Coaster Brake	Coaster Brake	
Hub Shell Material	6061 Aluminum	6061 Aluminum	6061 Aluminum	Steel	
Gear Ratio	Overall Range	256%		256%	
	1	62.5%	(-) 37.5%	62.5% (-) 37.5%	
	2	75%	(-) 25% [Gear 1 (+) 20%]	75% (-) 25% [Gear 1 (+) 20%]	
	3	100%	Direct Drive [Gear 2 (+) 33%]	100% Direct Drive [Gear 2 (+) 33%]	
	4	133.3%	(+)33.3% [Gear 3 (+) 33%]	133.3% (+)33.3% [Gear 3 (+) 33%]	
	5	160%	(+)60% [Gear 4 (+) 20%]	160% (+)60% [Gear 4 (+) 20%]	
Axle Diameter	13/32" Slotted		13/32" Slotted	13/32" Slotted	
Axle Length	175mm	175mm	175mm	175mm	
Over Locknut Dimension	127mm	127mm	127mm	127mm	
R: Axle Protrusion Length	24mm	24mm	24mm	24mm	
L: Axle Protrusion Length	24mm	24mm	24mm	24mm	
Spoke Holes	36H	36H	36H	36 H	
Pitch Circle Diameter	89.4mm	67.0mm	67.0mm	65.0mm	
Flange Width	61.4mm	68.3mm	68.3mm	67.5mm	
Center to Flange	Right Left	32.7mm 28.7mm	32.4mm 35.9mm	32.4mm 35.9mm	31.0mm 36.5mm
Spoke Compatibility	13G & 14G	13G & 14G	13G & 14G	14G	
Sprocket Teeth	13~22T	13~22T	12~22T	13~22T	
Chain Line: 1/8" Flat	49.8mm	49.8mm	49.8, 52.8mm	49.8mm	
Chain Line: 1/8" Dished	48.1, 51.5mm	48.1, 51.5mm	×	48.1, 51.5mm	
Chain Line: 3/32" Flat	49.4, 50.2mm	49.4, 50.2mm	50.2, 53.2mm	49.4, 50.2mm	
Chain Line: 3/32" Dished	47.7, 51.9mm	47.7, 51.9mm	×	47.7, 51.9mm	
Indicator Type	Yellow / Navy Blue*	Yellow / Navy Blue*	Yellow / Navy Blue*	Yellow / Navy Blue*	
Finish	Anodized Alloy	Anodized Alloy	Anodized Alloy	Painted Silver	
Weight	1,630g	1,510g	1,510g	1,600g	

*Navy Blue Indicator must be used when using HMN420 Short Guide Nut.

Internal Gear Hubs C30

Model Name		RX-RD3	RS-RF3
Model No.		IHC3T.XBSS.AA0	IHC3F.QBSS.AA0
Speed		3-Speed	
Type		70mm Drum Brake	Freewheel
Hub Shell Material		A356 Aluminum	6061 Aluminum
Gear Ratio	Overall Range	177%	
	1	75%	(-) 25%
	2	100%	Direct Drive [Gear 1 (+) 33%]
	3	133%	(+) 33.3% [Gear 2 (+) 33%]
Axle Diameter		3/8" Slotted	
Axle Length		185mm	185mm
Over Locknut Dimension		135mm	129mm
R:Axle Protusion Length		27mm	27mm
L:Axle Protusion Length		23mm	29mm
Spocke Holes		36H	36H
Pitch Circle Diameter		89.8mm	67.0mm
Flange Width		65.9mm	56.6mm
Center to Flange	Right	20.4mm	19.2mm
	Left	45.5mm	37.4mm
Spocke Compatibility		13G & 14G	13G & 14G
Sprocket Teeth		17~19T	17~19T
Chain Line:3mm 17T Dished		45.6mm	41.7mm
Finish		Natural Alloy	Anodized Alloy
Weight		1,400g	1,300g

Internal Gear Hubs S30

Model Name		XL-RD3	X-RD3	S-RK3	S-RK3 (N)
Model No. (36H)		IHS3T.YBSS.AA0	IHS3T.XBSS.AA1	IHS3K.QBLS.AA0	IHN3K.QBLS.AA0
Model No. (32H)		×	×	IHS3K.QCLS.AA0	IHN3K.QCLS.AA0
Model No. (High Polish)		IHS3T.YBSS.HA0	IHS3T.XBSS.HA1	×	×
Speed		3-Speed		3-Speed	
Type		90mm Drum Brake	70mm Drum Brake	Disc Brake Type	Disc Brake Type
Hub Shell Material		A356 Aluminum	A356 Aluminum	6061 Aluminum	6061 Aluminum
Gear Ratio	Overall Range	177%		177%	
	1	75%	(-) 25%	75%	(-) 25%
	2	100%	Direct Drive [Gear 1 (+) 33%]	100%	Direct Drive [Gear 1 (+) 33%]
	3	133%	(+) 33.3% [Gear 2 (+) 33%]	133%	(+) 33.3% [Gear 2 (+) 33%]
Axle Diameter		13/32" Slotted		13/32" Slotted	
Axle Length		177mm	163mm	185mm	185mm
Over Locknut Dimension		130mm	117mm	135mm	135mm
R: Axle Protrusion Length		26mm	23mm	24mm	24mm
L: Axle Protrusion Length		21mm	23mm	26mm	26mm
Spoke Holes		36H	36H	(B) 36H / (C) 32H	(B) 36H / (C) 32H
Pitch Circle Diameter		109.0mm	89.8mm	67.0mm	67.0mm
Flange Width		75.7mm	65.9mm	56.6mm	56.6mm
Center to Flange	Right	31.9mm	26.9mm	28.0mm	28.0mm
	Left	43.8mm	39.0mm	28.6mm	28.6mm
Spoke Compatibility		13G & 14G	13G & 14G	13G & 14G	13G & 14G
Sprocket Teeth		13~22T	13~22T	13~22T	12~22T
Chain Line: 1/8" Flat		50.9mm	44.7mm	43.9mm	43.9, 46.9mm
Chain Line: 1/8" Dished		49.3, 52.7mm	43.1, 46.5mm	42.3, 45.7mm	×
Chain Line: 3/32" Flat		50.6, 51.2mm	44.3, 45.1mm	43.5, 44.3mm	44.3, 47.3mm
Chain Line: 3/32" Dished		48.8, 53.0mm	42.6, 46.6mm	41.8, 45.8mm	×
Indicator Type		MK4	MK3	MK9	MK9
Finish		Natural Alloy	Natural Alloy	Anodized Alloy	Anodized Alloy
Weight		1,720g	1,400g	1,085g	1,080g

Internal Gear Hubs S30

Model Name	S-RC3 (II)		S-RF3				S-RF3(N)	
Model No. (36H)	IHS3C.QBLS.AA3	IHS3C.QBSS.AA3	IHS3F.QBLS.AA3	IHS3F.QBSA.AA3	IHS3F.QBSS.AA3	×	×	
Model No. (32H)	IHS3C.QCLS.AA3	IHS3C.QCSS.AA3	IHS3F.QCLS.AA3	IHS3F.QCSA.AA3	IHS3F.QCSS.AA3	×	×	
Model No. (28H)	×	IHS3C.QDSS.AA3	×	×	×	IHS3F.QDCS.AA3	IHN3F.QDCB.AA3	
Model No. (High Polish)	×	×	×	×	×	×	×	
Speed	3-Speed		3-Speed					
Type	Coaster Brake		Freewheel					
Hub Shell Material	6061 Aluminum		6061 Aluminum					
Gear Ratio	Overall Range	177%		177%				
	1	75%	(-) 25%	75%	(-) 25%			
	2	100%	Direct Drive [Gear 1 (+) 33%]	100%	Direct Drive [Gear 1 (+) 33%]			
	3	133%	(+) 33.3% [Gear 2 (+) 33%]	133%	(+) 33.3% [Gear 2 (+) 33%]			
Axle Diameter	13/32" Slotted		13/32" Slotted					
Axle Length	175mm	163mm	175mm	163mm	163mm	148mm	148mm	
Over Locknut Dimension	116mm	116mm	127mm	119mm	117mm	108mm	111mm	
R: Axle Protrusion Length	30mm	26mm	24mm	22mm	22mm	20mm	18mm	
L: Axle Protrusion Length	29mm	21mm	24mm	22mm	24mm	20mm	19mm	
Spoke Holes	(B) 36H / (C) 32H / (D) 28H		(B) 36H / (C) 32H	(B) 36H / (C) 32H	(B) 36H / (C) 32H	(D) 28H	28H	
Pitch Circle Diameter	67.0mm	67.0mm	67.0mm	67.0mm	67.0mm	67.0mm	67.0mm	
Flange Width	56.6mm	56.6mm	56.6mm	56.6mm	56.6mm	56.6mm	56.6mm	
Center to Flange	Right	26.3mm	26.3mm	28.6mm	28.6mm	28.6mm	28.0mm	25.6mm
	Left	30.3mm	30.3mm	28.0mm	28.0mm	28.0mm	28.6mm	31.0mm
Spoke Compatibility	13G & 14G	13G & 14G	13G & 14G	13G & 14G	13G & 14G	13G & 14G	13G & 14G	
Sprocket Teeth	13~22T	13~22T	13~22T	13~22T	13~22T	13~22T	12~22T	
Chain Line: 1/8" Flat	45.6mm	43.9mm	43.1mm	44.1mm	43.1mm	40 mm	40 , 43mm	
Chain Line: 1/8" Dished	44.0 , 47.4mm	42.3 , 45.7mm	41.5 , 44.9mm	42.5 , 45.9mm	41.5 , 44.9mm	38.4 , 41.8mm	×	
Chain Line: 3/32" Flat	45.2 , 46.0mm	43.5 , 44.3mm	42.7 , 43.5mm	43.7 , 44.5mm	42.7 , 43.5mm	39.6 , 40.4mm	40.4 , 43.4mm	
Chain Line: 3/32" Dished	43.5 , 47.5mm	41.8 , 45.8mm	41.0 , 45.0mm	42.0 , 46.0mm	41.0 , 45.0mm	37.9 , 41.9mm	×	
Indicator Type	MK5	MK4	MK5	MK3	MK3	MK2	MK2	
Finish	Anodized Alloy	Anodized Alloy	Anodized Alloy	Anodized Alloy	Anodized Alloy	Anodized Alloy	Anodized Alloy	
Weight	1,300g	1,290g	1,015g	995g	995g	975g	970g	

Internal Gear Hubs S3S

Model Name	AB3	SAB3	AWC (II)		AW3		
Model No.	IHS3T.LBSS.SA4	IHS3T.SBSS.SA3	IHS3C.WBLS.SA3	IHS3C.WBSS.SA3	IHS3F.WBLS.SA3	IHS3F.WBSS.SA3	IHS3F.WDCS.SA3
Speed	3-Speed		3-Speed		3-Speed		
Type	90mm Drum Brake	70mm Drum Brake	Coaster Brake		Freewheel		
Hub Shell Material	Steel	Steel	Steel		Steel		
Gear Ratio	Overall Range	177%		177%		177%	
	1	75%	(-) 25%	75%	(-) 25%	75%	(-) 25%
	2	100%	Direct Drive [Gear 1 (+) 33%]	100%	Direct Drive [Gear 1 (+) 33%]	100%	Direct Drive [Gear 1 (+) 33%]
	3	133%	(+) 33.3% [Gear 2 (+) 33%]	133%	(+) 33.3% [Gear 2 (+) 33%]	133%	(+) 33.3% [Gear 2 (+) 33%]
Axle Diameter	13/32" Slotted		13/32" Slotted		13/32" Slotted		
Axle Length	163mm	163mm	175mm	163mm	175mm	163mm	148mm
Over Locknut Dimension	117mm	118mm	116mm	116mm	127mm	117mm	108mm
R: Axle Protrusion Length	23mm	24mm	30mm	26mm	24mm	22mm	20mm
L: Axle Protrusion Length	23mm	21mm	29mm	21mm	24mm	24mm	20mm
Spoke Holes	36H	36H	36H	36H	36H	36H	28H
Pitch Circle Diameter	65.5mm 102.8mm	65mm 82.7mm	65.0mm	65.0mm	65.0mm	65.0mm	65.0mm
Flange Width	68.4mm	66.0mm	56.6mm	56.6mm	56.6mm	56.6mm	56.6mm
Center to Flange	Right	27.2mm	27.3mm	26.3mm	26.3mm	28.6mm	28.0mm
	Left	41.2mm	38.7mm	30.3mm	30.3mm	28.0mm	28.6mm
Spoke Compatibility	13G & 14G	13G & 14G	14G	14G	14G	14G	14G
Sprocket Teeth	13~22T	13~22T	13~22T	13~22T	13~22T	13~22T	13~22T
Chain Line: 1/8" Flat	44.6mm	45.4mm	45.6mm	43.9mm	43.1mm	43.1mm	40mm
Chain Line: 1/8" Dished	43.0 , 46.4mm	43.8 , 47.2mm	44.0 , 47.4mm	42.3 , 45.7mm	41.5 , 44.9mm	41.5 , 44.9mm	38.4 , 41.8mm
Chain Line: 3/32" Flat	44.2 , 45.0mm	45.0 , 45.8mm	45.2 , 46.0mm	43.5 , 44.3mm	42.7 , 43.5mm	42.7 , 43.5mm	39.6 , 40.4mm
Chain Line: 3/32" Dished	42.5 , 46.5mm	43.3 , 47.3mm	43.5 , 47.5mm	41.8 , 45.8mm	41.0 , 45.0mm	41.0 , 45.0mm	37.9 , 41.9mm
Indicator Type	MK3	MK3	MK5	MK4	MK5	MK3	MK2
Finish	Painted Silver	Painted Silver	Painted Silver	Painted Silver	Painted Silver	Painted Silver	Painted Silver
Weight	1,570g	1,410g	1,360g	1,350g	1,115g	1,095g	1,075g

Internal Gear Hubs SX

Model Name	SX-RK3		SX-RB3	
Model No.	IHS3K.PBSS.AA1		IHS3B.PBSS.AAA	
Speed	3-Speed			
Type	Disc Brake		Band / Servo Brake	
Hub Shell Material	6061 Aluminum		A356 Aluminum	
Gear Ratio	Overall Range	177%		
	1	75%	(-) 25%	
	2	100%	Direct Drive [Gear 1 (+) 33%]	
	3	133%	(+ 33.3% [Gear 2 (+) 33%]	
Axle Diameter	13/32" Slotted			
Axle Length	215mm		215mm	
Over Locknut Dimension	170mm		163mm	
R: Axle Protrusion Length	23mm		23mm	
L: Axle Protrusion Length	22mm		29mm	
Spoke Holes	36H		36H	
Pitch Circle Diameter	89.8mm		90.0mm	
Center to Flange	Right	52.1mm		47.2mm
	Left	43.5mm		46.3mm
Flange Width	95.6mm		93.5mm	
Spoke Compatibility	13G & 14G		13G & 14G	
Sprocket Teeth	13~22T		13~22T	
Chain Line: 1/8" Flat	70.9mm		67.6 mm	
Chain Line: 1/8" Dished	69.2 , 72.6mm		65.9 , 69.3mm	
Chain Line: 3/32" Flat	70.6 , 71.2mm		67.3 , 67.9mm	
Chain Line: 3/32" Dished	68.8 , 73.0mm		65.5 , 69.7mm	
Indicators	MK3		MK3	
Weight	1,400g		1,240g	

Internal Gear Hubs TS & QS

Model Name	TS-RF3	TS-RB3	TS-RC3	QS-RC3	TS-RF5	TS-RC5	QS-RC5
Model No.	IHT3F.QBSS.AA3	IHT3B.QBSS.AA3	IHT3C.QBSS.AA3	IHQ3C.QBLS.AA3	IHT5F.QBSC.AA1	IHT5C.QBSS.AA1	IHQ5C.QBLS.AA3
Speed	3-Speed	3-Speed	3-Speed	3-Speed + Reverse	5-Speed	5-Speed	5-Speed + Reverse
Type	Freewheel	Band Brake	Coaster Brake	Coaster Brake	Freewheel	Coaster Brake	Coaster Brake
Hub Shell Material	6061 Aluminum	6061 Aluminum	6061 Aluminum	6061 Aluminum	6061 Aluminum	6061 Aluminum	6061 Aluminum
Gear Ratio	Overall Range	177%			256%		
	1	75% (-) 25%			62.5% (-) 37.5%		
	2	100% Direct Drive [Gear 1 (+) 33%]			75% (-) 25% [Gear 1 (+) 20%]		
	3	133% (+) 33.3% [Gear 2 (+) 33%]			100% Direct Drive [Gear 2 (+) 33%]		
	4	×			133.3% (+) 33.3% [Gear 3 (+) 33%]		
	5	×			160% (+) 60% [Gear 4 (+) 20%]		
Axle Diameter	13/32" Slotted	13/32" Slotted	13/32" Slotted	13/32" Slotted	13/32" Slotted	13/32" Slotted	13/32" Slotted
Axle Length	163mm	163mm	163mm	175mm	175mm	175mm	185mm
Over Locknut Dimension	117mm	113mm	116mm	126mm	116mm	127mm	139mm
R: Axle Protrusion Length	22mm	23mm	26mm	30mm	24mm	24mm	24mm
L: Axle Protrusion Length	24mm	27mm	21mm	19mm	35mm	24mm	22mm
Flange Sprocket Teeth	22T	22T	22T	22T	22T	22T	22T
Flange Sprocket C.L.	30.1mm	32.8mm	27.8mm	33.4mm	27.6mm	33.9mm	39.4mm
Sprocket Teeth	21~22T	21~22T	21~22T	21~22T	21~22T	21~22T	21~22T
Sprocket Chain Line	44.9mm	46.0mm	45.7mm	47.2mm	44.2mm	51.5mm	53.9mm
Indicators	MK3	MK3	MK4	MK5	Yellow / Navy Blue*	Yellow / Navy Blue*	Yellow / Navy Blue*
Finish	Anodized Alloy	Anodized Alloy	Anodized Alloy	Anodized Alloy	Anodized Alloy	Anodized Alloy	Anodized Alloy
Weight	1,100g	1,010g	1,360g	1,800g	1,320g	1,580g	2,010g

*Navy Blue Indicator must be used when using HMN420 Short Guide Nut.

Internal Gear Hubs S3X

Model Name		S3X	
Model No. (Alloy Silver 36H)	IHS3X.QBSS.AA0	IHS3X.QBLS.AA0	
Model No. (Alloy Silver 32H)	IHS3X.QCSS.AA0	IHS3X.QCLS.AA0	
Model No. (Black 36H)	IHS3X.QBSS.BA0	IHS3X.QBLS.BA0	
Model No. (Black 32H)	IHS3X.QCSS.BA0	IHS3X.QCLS.BA0	
Model No. (Gold 36H)	IHS3X.QBSS.GA0	IHS3X.QBLS.GA0	
Model No. (Gold 32H)	IHS3X.QCSS.GA0	IHS3X.QCLS.GA0	
Model No. (Red 36H)	IHS3X.QBSS.RA0	IHS3X.QBLS.RA0	
Model No. (Red 32H)	IHS3X.QCSS.RA0	IHS3X.QCLS.RA0	
Model No. (Blue 36H)	IHS3X.QBSS.2A0	IHS3X.QBLS.2A0	
Model No. (Blue 32H)	IHS3X.QCSS.2A0	IHS3X.QCLS.2A0	
Model No. (Purple 36H)	IHS3X.QBSS.3A0	IHS3X.QBLS.3A0	
Model No. (Purple 32H)	IHS3X.QCSS.3A0	IHS3X.QCLS.3A0	
Type	Fixed Gear		
Speed	3-Speed		
Hub Shell Material	6061 Aluminum		
Gear Ratio	Overall Range	160%	
	1	62.5%	(-) 37.5%
	2	75%	(-) 25% [Gear 1 (+) 20%]
	3	100%	Direct Drive [Gear 2 (+) 33%]
Axle Diameter	13/32" Slotted		
Axle Length	165mm	174mm	
Over Locknut Dimension	120mm	130mm	
R: Axle Protrusion Length	22mm	21mm	
L: Axle Protrusion Length	23mm	23mm	
Spoke Holes	(B) 36H / (C) 32H		
Pitch Circle Diameter	67.0mm	67.0mm	
Flange Width	56.6mm	56.6mm	
Center to Flange	Right	24.7mm	24.0mm
	Left	31.9mm	32.6mm
Spoke Compatibility	14G	14G	
Sprocket Teeth 1/8"	13~22T	13~22T	
Sprocket Teeth 3/32"	12~22T	12~22T	
Chain Line	42 , 43 , 44 , 45mm	42 , 43 , 44 , 45mm	
Indicator	Orange	White	
Finish	High Polish Double Anodized		
Weight	980g	990g	

Internal Gear Hubs F30

Model Name		CS-RF3			CS-RK3		
Model No. (Alloy Silver 36H)		IHF3F.QBSS.AA0	IHF3F.QCSS.AA0	IHF3F.QDSS.AA0	IHF3K.QBSS.AA0	IHF3K.QCSS.AA0	IHF3K.QDSS.AA0
Model No. (Black 36H)		IHF3F.QBSS.BA0	IHF3F.QCSS.BA0	IHF3F.QDSS.BA0	IHF3K.QBSS.BA0	IHF3K.QCSS.BA0	IHF3K.QDSS.BA0
Speed		3 x 9/8-Speed			3 x 9/8-Speed		
Type		Freewheel			Disc Brake Type		
Hub Shell Material		6061 Aluminum			6061 Aluminum		
Gear Ratio	Overall Range	177%			177%		
	1	75%	(-) 25%		75%	(-) 25%	
	2	100%	Direct Drive	[Gear 1 (+) 33%]	100%	Direct Drive	[Gear 1 (+) 33%]
	3	133%	(+) 33.3%	[Gear 2 (+) 33%]	133%	(+) 33.3%	[Gear 2 (+) 33%]
Axle Diameter		13/32" Slotted			13/32" Slotted		
Axle Length		179mm			179mm		
Over Locknut Dimension		135mm			135mm		
R: Axle Protrusion Length		22mm			22mm		
L: Axle Protrusion Length		22mm			22mm		
Spoke Holes		36H	32H	28H	36H	32H	28H
Pitch Circle Diameter		67.0mm			67.0mm		
Flange Width		56.6mm			56.6mm		
Center to Flange	Right	21.4mm			21.4mm		
	Left	35.4mm			35.4mm		
Spoke Compatibility		13G & 14G			13G & 14G		
Cassette Sprocket Type		9/8-Speed			9/8-Speed		
Max. Sprocket		34T			34T		
Min. Sprocket		11T			11T		
Chain Line:		45mm			45mm		
Indicators		MK8			MK8		
Finish		Anodized Alloy			Anodized Alloy		
Weight		1,090g			1,155g		

Internal Gear Hubs S20 / S2S

Model Name	S2		S2C	B2C
Model No. (Alloy Silver 36H)	IHK2F.QBSS.AA0	IHK2F.QBCS.AA0	IHK2C.QBSS.AA1	×
Model No. (Alloy Silver 32H)	IHK2F.QCSS.AA0	IHK2F.QCCS.AA0	IHK2C.QCSS.AA1	×
Model No. (Black 36H)	IHK2F.QBSS.BA0	IHK2F.QBCS.BA0	IHK2C.QBSS.BA1	IHK2C.WBSS.BA0
Model No. (Black 32H)	IHK2F.QCSS.BA0	IHK2F.QCCS.BA0	IHK2C.QCSS.BA1	×
Model No. (Gold 36H)	IHK2F.QBSS.GA0	IHK2F.QBCS.GA0	IHK2C.QBSS.GA1	×
Model No. (Gold 32H)	IHK2F.QCSS.GA0	IHK2F.QCCS.GA0	IHK2C.QCSS.GA1	×
Model No. (Red 36H)	IHK2F.QBSS.RA0	IHK2F.QBCS.RA0	IHK2C.QBSS.RA1	×
Model No. (Red 32H)	IHK2F.QCSS.RA0	IHK2F.QCCS.RA0	IHK2C.QCSS.RA1	×
Model No. (Blue 36H)	IHK2F.QBSS.2A0	IHK2F.QBCS.2A0	IHK2C.QBSS.2A1	×
Model No. (Blue 32H)	IHK2F.QCSS.2A0	IHK2F.QCCS.2A0	IHK2C.QCSS.2A1	×
Model No. (Purple 36H)	IHK2F.QBSS.3A0	IHK2F.QBCS.3A0	IHK2C.QBSS.3A1	×
Model No. (Purple 32H)	IHK2F.QCSS.3A0	IHK2F.QCCS.3A0	IHK2C.QCSS.3A1	×
Speed	2-Speed		2-Speed	2-Speed
Type	Freewheel		Coaster Brake	Coaster Brake
Hub Shell Material	6061 Aluminum		6061 Aluminum	Steel
Gear Ratio	Overall Range	138%		138%
	1	100%	Direct Drive	100% Direct Drive
	2	138%	(+)38% [Gear 1 (+) 38%]	138% (+)38% [Gear 1 (+) 38%]
Axle Diameter	13/32" Slotted		13/32" Slotted	
Axle Length	160mm	148mm	162mm	162mm
Over Locknut Dimension	120mm	110mm	116mm	116mm
R: Axle Protrusion Length	20mm	19mm	23mm	23mm
L: Axle Protrusion Length	20mm	19mm	23mm	23mm
Spoke Holes	(B) 36H / (C) 32H		(B) 36H / (C) 32H	36H
Pitch Circle Diameter	67.0mm		67.0mm	65.0mm
Flange Width	56.6mm		56.6mm	56.6mm
Center to Flange	Right	28.3mm	26.5mm	26.9mm
	Left	28.3mm	30.1mm	29.7mm
Spoke Compatibility	13G & 14G		13G & 14G	14G
Sprocket Teeth	13~22T		13~24T	
Chain Line: 1/8" Flat	42.7mm	41.1mm	43mm	43mm
Chain Line: 1/8" Dished	40.9, 44.5mm	39.3, 42.9mm	41.2, 44.8mm	41.2, 44.8mm
Chain Line: 3/32" Flat	42.3, 43.1mm	40.7, 41.5mm	42.6, 43.4mm	42.6, 43.4mm
Chain Line: 3/32" Dished	40.6, 44.8mm	39.0, 43.2mm	41.1, 44.9mm	41.1, 44.9mm
Finish	Hi-Polished Anodized		Hi-Polish Anodized	Painted Black
Weight	930g	920g	1,400g	1,390g

HBT Hubs

Model Name	HBT30 Front			HBT30 Rear		
Model No. (Alloy Silver)	HBT30.F0AB.AA0	HBT30.F0AC.AA0	HBT30.F0AD.AA0	HBT30.RRAB.AA0	HBT30.RRAC.AA0	HBT30.RRAD.AA0
Model No. (Black)	HBT30.F0AB.BA0	HBT30.F0AC.BA0	HBT30.F0AD.BA0	HBT30.RRAB.BA0	HBT30.RRAC.BA0	HBT30.RRAD.BA0
Model No. (Gold)	HBT30.F0AB.GA0	HBT30.F0AC.GA0	HBT30.F0AD.GA0	HBT30.RRAB.GA0	HBT30.RRAC.GA0	HBT30.RRAD.GA0
Model No. (Red)	HBT30.F0AB.RA0	HBT30.F0AC.RA0	HBT30.F0AD.RA0	HBT30.RRAB.RA0	HBT30.RRAC.RA0	HBT30.RRAD.RA0
Model No. (Blue)	HBT30.F0AB.2A0	HBT30.F0AC.2A0	HBT30.F0AD.2A0	HBT30.RRAB.2A0	HBT30.RRAC.2A0	HBT30.RRAD.2A0
Model No. (Purple)	HBT30.F0AB.3A0	HBT30.F0AC.3A0	HBT30.F0AD.3A0	HBT30.RRAB.3A0	HBT30.RRAC.3A0	HBT30.RRAD.3A0
Hub Shell Material	6061 Aluminum			6061 Aluminum		
Bearing	Sealed Cartridge Bearing (2)			Sealed Cartridge Bearing (2)		
Axle Material	Chromoly			Chromoly		
Axle Diameter	9mm			10mm		
Axle Length	145mm			175mm		
Over Lock Dimension	100mm			130mm		
Spoke Holes	36H	32H	28H	36H	32H	28H
Pitch Circle Diameter	61.5mm			61.5mm		
Flange Width	70.6mm			66.6mm		
Center to Flange	Right	35.3mm	35.3mm	35.3mm	33.3mm	33.3mm
	Left	35.3mm	35.3mm	35.3mm	33.3mm	33.3mm
Finish	Hi-Polish Anodized			Hi-Polish Anodized		
Average Weight	273g			343g		

Front Drum Brake Hubs

Model Name	XL-FD	X-FD	BF	SBF
Model No.	THSLD.FBSS.AA0	THSXD.FBSS.AA1	THSLB.FBSS.SA4	THSSB.FBSS.SA0
Model No. (High Polish)	THSLD.FBSS.HA0	THSXD.FBSS.HA1	×	×
Brake Type	90mm Drum Brake	70mm Drum Brake	90mm Drum Brake	70mm Drum Brake
Hub Shell Material	A356 Aluminum	A356 Aluminum	Steel	Steel
Bearing Type	Sealed Cartridge	Sealed Cartridge	Loose Ball	Loose Ball
Axle Type	Solid Nutted	Solid Nutted	Solid Nutted	Solid Nutted
Axle Diameter	9mm	9mm	3/8" (26TPI) Slotted	3/8" (26TPI) Slotted
Axle Length	136mm	136mm	136mm	136mm
Over Locknut Dimension	100mm	100mm	100mm	100mm
Spoke Holes	36H	36H	36H	36H
Pitch Circle Diameter	109.0mm	89.8mm	48.5mm 102.5mm	83.0mm
Flange Width	58mm	58mm	59.4mm	56.0mm
Center to Flange	Right	32.0mm	29mm	31.1mm
	Left	26.0mm	29mm	28.3mm
Spoke Compatibility	13G & 14G	13G & 14G	13G & 14G	14G
Finish	Natural Alloy	Natural Alloy	Painted Silver	Painted Silver
Weight	970g	770g	1,020g	880g

Rear Drum Brake Hubs

Model Name	X-RD		X-RDC	
Model No.	THSXD.RBSS.AA0	THSXD.7BSS.AA0	THSXD.CBQS.AA0	THSXD.CBSS.AA0
Brake Type	70mm Drum Brake		70 mm Drum Brake	
Usage	1-Speed Freewheel	7-Speed Freewheel	9/8-Speed Cassette	
Hub Shell Material	A356 Aluminum		A356 Aluminum	
Bearing Type	Sealed Cartridge	Sealed Cartridge	Sealed Cartridge	Sealed Cartridge
Axle Type	Solid Notted	Solid Notted	Quick-Release	Solid Notted
Axle Diameter	9mm	9mm	10mm	10mm
Axle Length	183mm	183mm	145mm	175mm
Over Locknut Dimension	135mm	135mm	135mm	135mm
R: Axle Protrusion Length	31mm	24mm	5mm	20mm
L: Axle Protrusion Length	17mm	24mm	5mm	20mm
D-Dimension	31mm	38mm	41mm	41mm
Spoke Holes	36H	36H	36H	36H
Pitch Circle Diameter	89.8mm	89.8mm	89.8mm	89.8mm
Flange Width	64.2mm	64.2mm	64.2mm	64.2mm
Center to Flange	Right	27.8mm	20.7mm	20.4mm
	Left	36.4mm	43.5mm	43.8mm
Spoke Compatibility	13G & 14G	13G & 14G	13G & 14G	13G & 14G
Finish	Natural Alloy	Natural Alloy	Natural Alloy	Natural Alloy
Weight	835g	835g	995g	950g

Side Drum Brake Hubs

Model Name	XL-SD					
Model No.	THH90.LBQS.AA1	THH90.RBQS.AA1	THH80.LBSS.AA2	THH80.RBSS.AA2	THH80.LBCS.AA2	THH80.RBCS.AA2
Model No. (High Polish)	THH90.LBQS.HA1	THH90.RBQS.HA1	×	×	×	×
Brake Type	90mm Drum Brake		90mm Drum Brake		90mm Drum Brake	
Side	Left	Right	Left	Right	Left	Right
Axle Type	HSL819 Quick-Release		HSL881 Solid Nuted		HSL885 Solid Nuted	
Axle Diameter / Type	12mm (16mm Base)		12mm		12mm	
Axle Length	150mm		130mm (excl. M19 Hex Bolt Head of 4mm)		100mm (excl. M19 Hex Bolt Head of 4mm)	
Axle Protrusion Length	62mm (incl.12mm QR protrusion from base)		50mm		20mm	
Hub Shell Material	A356 Aluminum		A356 Aluminum		A356 Aluminum	
Bearing Type	6001-ZZ Sealed Cartridge x2		6001-ZZ Sealed Cartridge x2		6001-ZZ Sealed Cartridge x2	
Spoke Holes	36H		36H		36H	
Pitch Circle Diameter	109.0mm		109.0mm		109.0mm	
Flange Width	53mm		53mm		53mm	
Spoke Compatibility	13G & 14G		13G & 14G		13G & 14G	
Finish	Natural Alloy		Natural Alloy		Natural Alloy	
Weight	1,020g	1,020g	960g	960g	935g	935g

Model Name	X-SD [X-FD(H)]					
Model No.	THH60.LBQS.AA1	THH60.RBQS.AA1	THH50.LBSS.AA2	THH50.RBSS.AA2	THH50.LBCS.AA2	THH50.RBCS.AA2
Brake Type	70mm Drum Brake		70mm Drum Brake		70mm Drum Brake	
Side	Left	Right	Left	Right	Left	Right
Axle Type	HSL819 Quick-Release		HSL881 Solid Nuted		HSL885 Solid Nuted	
Axle Diameter / Type	12mm (16mm Base)		12mm		12mm	
Axle Length	150mm		130mm (excl. M19 Hex Bolt Head of 4mm)		100mm (excl. M19 Hex Bolt Head of 4mm)	
Axle Protrusion Length	62mm (incl.12mm QR protrusion from base)		50mm		20mm	
Hub Shell Material	A356 Aluminum		A356 Aluminum		A356 Aluminum	
Bearing Type	6001-ZZ Sealed Cartridge x2		6001-ZZ Sealed Cartridge x2		6001-ZZ Sealed Cartridge x2	
Spoke Holes	36H		36H		36H	
Pitch Circle Diameter	89.8mm		89.8mm		89.8mm	
Flange Width	54mm		54mm		54mm	
Spoke Compatibility	13G & 14G		13G & 14G		13G & 14G	
Finish	Natural Alloy		Natural Alloy		Natural Alloy	
Weight	790g	790g	730g	730g	705g	705g

Front Cranksets FCS

Model No.	FCSX6	FCSX4
Number of Teeth	36T	34T
Chainring Material	7075 Aluminum / Anodized + CNC	
Removable Chainring	●	
Crank Arm Spline Type	Integrated ISIS External BB	
Crank Arm Material	Forged Aluminum	
Axle Material	Chromoly	
Axle Diameter	Ø 24mm	
Axle Bolt	7075 Aluminum	
Crank Arm Length	172.5mm	
Chainring Bolts / Nuts	7075 Aluminum	
Bolt Circle Diameter	110mm	
Bottom Bracket (Included)	Model	BBS (A1)
	Shell 'W'	BSA 68mm
	Chain Line	45mm
	Weight	125g
Weight (Right)	474g	470g
Weight (Left)	260g	260g
Total Weight	859g	855g

Model No.	FCSS2	FCSS1	
Number of Teeth	56T Flat	54T Flat or Dished*	
Chainring Material	Aluminum		
Removable Chainring	●		
Crank Style	Polished 5-Arm Spider		
Crank Arm Material	Forged Aluminum		
Crank Arm Length	170mm		
Chainring Bolts / Nuts	SCM435 Chromoly		
Bolt Circle Diameter	130mm		
Chainguard Outer	Aluminum	Aluminum	
Chainguard Inner	×	Aluminum	
Bottom Bracket (Optional)	Model	BBS18 / BBS15 (Sun Race)	
	Shell 'W'	(S) 68mm	(S) 68mm
	Spindle 'L'	(K) 119mm	(G) 113 / (K) 119mm*
	Chain Line	45.0mm	45.0mm
Weight (Right)	435g	425g	
Weight (Left)	205g	205g	
Total Weight	640g	630g	

*CG versions require Dished Chainring and 113mm Spindle.

Model No.	FCS74	FCS73	FCS72	FCS71	FCS70	FCS7B
Number of Teeth	44T	44T	44T	42T	42T	42T
Chainring Material	Aluminum	Hi-Tensile Steel	Hi-Tensile Steel	Hi-Tensile Steel	Hi-Tensile Steel	Hi-Tensile Steel
Removable Chainring	●	●	●	●	●	●
Crank Style	4-Arm Spider A-Crank			4-Arm Spider A-Crank		
Crank Arm Material	A356.2 Aluminum			A356.2 Aluminum		
Crank Arm Length	175mm / 170mm			175mm / 170mm		
Chainring Bolts / Nuts	SCM435 Chromoly	SCM435 Chromoly	SCM435 Chromoly	SCM435 Chromoly	SCM435 Chromoly	SUS302
Bolt Circle Diameter	104mm	104mm	104mm	104mm	104mm	104mm
Chainguard Outer	Aluminum	Aluminum	Hi-Tensile Steel	Aluminum	Hi-Tensile Steel	Aluminum
Chainguard Inner	Hi-Tensile Steel	Hi-Tensile Steel	Hi-Tensile Steel	Hi-Tensile Steel	Hi-Tensile Steel	×
Bottom Bracket (Optional)	Model	BBS18 / BBS15 (Sun Race)			BBS18 / BBS15 (Sun Race)	
	Shell 'W'	(S) 68mm			(S) 68mm	
	Spindle 'L'	(F) 111mm			(F) 111mm	
	Chain Line	45.0mm			45.0mm	
Weight (Right)	400g	510g	610g	505g	595g	475g
Weight (Left)	210g	210g	210g	210g	210g	210g
Total Weight	610g	720g	820g	715g	805g	685g

*CG versions require Dished Chainring and 113mm Spindle.

Front Cranksets FCS

Model No.	FCS81	FCS80	FCSA8	FCSA6	FCSA3	FCSB8
Number of Teeth	33T	30T	38T	36T	33T	38T
Chainring Material	Hi-Tensile Steel	Hi-Tensile Steel	Hi-Tensile Steel	Hi-Tensile Steel	Hi-Tensile Steel	Hi-Tensile Steel
Crank Style	I-Crank		A-Crank			A-Crank
Crank Arm Material	A356.2 Aluminum		A356.2 Aluminum			A356.2 Aluminum
Crank Arm Length	175mm / 170mm		170mm			170mm
Cover Ring Diameter	92mm		95mm			95mm
Chain Size	1/2" x 1/8"		1/2" x 3/32"			1/2" x 1/8"
Chain Guard Option	X		X			X
Bottom Bracket (Optional)	Model	BBS15 (Sun Race)		BBS15 (Sun Race)		BBS15 (Sun Race)
	Shell 'W'	(S) 68mm		(S) 68mm		(S) 68mm
	Spindle 'L'	(5) 115mm		(H) 122mm		(H) 122mm
	Chain Line	45.0mm		45.0mm		45.0mm
Weight (Right)	451g	430g	442g	428g	407g	536g
Weight (Left)	240g	240g	215g	215g	215g	215g
Total Weight	691g	670g	657g	643g	622g	751g

Model No.	FCS52	FCS51	FCS50	FCS32	FCS31	FCS30
Number of Teeth	38T	36T	33T	38T	36T	33T
Chainring Material	Hi-Tensile Steel	Hi-Tensile Steel	Hi-Tensile Steel	Hi-Tensile Steel	Hi-Tensile Steel	Hi-Tensile Steel
Crank Style	I-Crank			A-Crank		
Crank Arm Material	A356.2 Aluminum			A356.2 Aluminum		
Crank Arm Length	175mm / 170mm			175/170/165/160/152mm		
Cover Ring Diameter	92mm			92mm		
Chain Size	1/2" x 3/32"			1/2" x 3/32"		
Chain Guard Option	●	X	X	●	X	X
Bottom Bracket (Optional)	Model	BBS15 (Sun Race)		BBS15 (Sun Race)		
	Shell 'W'	(S) 68mm		(S) 68mm		
	Spindle 'L'	(N) 122mm		(N) 122mm		
	Chain Line	45.0mm		45.0mm		
Weight (Right)	445g	431g	410g	410g (170)	396g (170)	375g (170)
Weight (Left)	240g	240g	240g	215g (170)	215g (170)	215g (170)
Total Weight	685g	671g	650g	625g (170)	611g (170)	590g (170)

Front Cranksets FCT

Model No.	FCT68		FCT66		FCT64		FCT62		
Crank Arm Spline Type	Square Taper		Square Taper		Square Taper		Square Taper		
Number of Teeth	48T		46T		44T		42T		
Chainring Material	7075 Aluminum								
Chainring Finish	(A) High Polish Anodized Alloy Silver / (D) Anodized Black + CNC								
Crank Arm Material	Forged Aluminum								
Crank Arm Finish	High Polish Anodized (A) Alloy / (B) Black / (G) Gold / (R) Red / (2) Blue / (3) Purple								
Crank Arm Length	172.5 / 170 / 165mm		172.5 / 170 / 165mm		172.5 / 170 / 165mm		172.5 / 170 / 165mm		
Chainring Bolts & Nuts	7075 Aluminum / Anodized		7075 Aluminum / Anodized		7075 Aluminum / Anodized		7075 Aluminum / Anodized		
Bolt Circle Diameter	144mm		144mm		144mm		144mm		
Chain Size	1/2" x 1/8"		1/2" x 1/8"		1/2" x 1/8"		1/2" x 1/8"		
Bottom Bracket (Optional)	Model	BBS18		BBS18		BBS18		BBS18	
	Shell 'W'	(S) 68mm		(S) 68mm		(S) 68mm		(S) 68mm	
	Spindle 'L'	(A) 103mm	(B) 107mm	(A) 103mm	(B) 107mm	(A) 103mm	(B) 107mm	(A) 103mm	(B)107mm
	Chain Line	42.0mm	43.5mm	42.0mm	43.5mm	42.0mm	43.5mm	42.0mm	43.5mm
Weight (R)	455g (170)		447g (170)		424g (170)		426g (170)		
Weight (L)	238g (170)		238g (170)		238g (170)		238g (170)		
Total Average Weight	693g (170)		685g (170)		662g (170)		664g (170)		

Model No.	FCT48		FCT46		FCT44		FCT42		
Crank Arm Spline Type	Square Taper		Square Taper		Square Taper		Square Taper		
Number of Teeth	48T		46T		44T		42T		
Chainring Material	7075 Aluminum								
Chainring Finish	Anodized Black + CNC								
Crank Arm Material	Forged Aluminum								
Crank Arm Finish	High Polish Anodized (A) Alloy Silver / (B) Black								
Crank Arm Length	172.5 / 170 / 165mm		172.5 / 170 / 165mm		172.5 / 170 / 165mm		172.5 / 170 / 165mm		
Chainring Bolts & Nuts	7075 Aluminum / Anodized		7075 Aluminum / Anodized		7075 Aluminum / Anodized		7075 Aluminum / Anodized		
Bolt Circle Diameter	144mm		144mm		144mm		144mm		
Chain Size	1/2" x 1/8"		1/2" x 1/8"		1/2" x 1/8"		1/2" x 1/8"		
Bottom Bracket (Optional)	Model	BBS18		BBS18		BBS18		BBS18	
	Shell 'W'	(S) 68mm		(S) 68mm		(S) 68mm		(S) 68mm	
	Spindle 'L'	(A) 103mm	(B) 107mm	(A) 103mm	(B) 107mm	(A) 103mm	(B) 107mm	(A) 103mm	(B)107mm
	Chain Line	42.0mm	43.5mm	42.0mm	43.5mm	42.0mm	43.5mm	42.0mm	43.5mm
Weight (R)	527g (170)		499g (170)		476g (170)		450g (170)		
Weight (L)	238g (170)		238g (170)		238g (170)		238g (170)		
Total Average Weight	765g (170)		737g (170)		714g (170)		688g (170)		

Front Cranksets FCT

Model No.	FCT28	FCT26	FCT24	FCT22
Crank Arm Spline Type	Square Taper	Square Taper	Square Taper	Square Taper
Number of Teeth	48T	46T	44T	42T
Chainring Material	7075 Aluminum			
Chainring Finish	Anodized Black + CNC			
Crank Arm Material	Forged Aluminum			
Crank Arm Finish	Hi-Polish Anodized (A) Alloy Silver / (B) Black			
Crank Arm Length	172.5 / 170 / 165mm	172.5 / 170 / 165mm	172.5 / 170 / 165mm	172.5 / 170 / 165mm
Chainring Bolts & Nuts	SCM435 Chromoly	SCM435 Chromoly	SCM435 Chromoly	SCM435 Chromoly
Bolt Circle Diameter	130mm	130mm	130mm	130mm
Chain Size	1/2" x 1/8"	1/2" x 1/8"	1/2" x 1/8"	1/2" x 1/8"
Bottom Bracket (Optional)	Model	BBS15	BBS15	BBS15
	Shell 'W'	(S) 68mm	(S) 68mm	(S) 68mm
	Spindle 'L'	(A) 103mm	(A) 103mm	(A) 103mm
	Chain Line	43.5mm	43.5mm	43.5mm
Weight (R)	566g (170)	541g (170)	516g (170)	491g (170)
Weight (L)	210g (170)	210g (170)	210g (170)	210g (170)
Total Average Weight	776g (170)	751g (170)	726g (170)	701g (170)

Model No.	FCT18	FCT16	FCT14	FCT12
Crank Arm Spline Type	Square Taper	Square Taper	Square Taper	Square Taper
Number of Teeth	48T	46T	44T	42T
Chainring Material	7075 Aluminum			
Chainring Finish	Anodized Black + CNC			
Crank Arm Material	Forged Aluminum			
Crank Arm Finish	Sandblast Anodized Matt Black			
Crank Arm Length	172.5 / 170 / 165mm	172.5 / 170 / 165mm	172.5 / 170 / 165mm	172.5 / 170 / 165mm
Chainring Bolts & Nuts	SCM435 Chromoly	SCM435 Chromoly	SCM435 Chromoly	SCM435 Chromoly
Bolt Circle Diameter	130mm	130mm	130mm	130mm
Chain Size	1/2" x 1/8"	1/2" x 1/8"	1/2" x 1/8"	1/2" x 1/8"
Bottom Bracket (Optional)	Model	BBS15	BBS15	BBS15
	Shell 'W'	(S) 68mm	(S) 68mm	(S) 68mm
	Spindle 'L'	(A) 103mm	(A) 103mm	(A) 103mm
	Chain Line	43.5mm	43.5mm	43.5mm
Weight (R)	568g (170)	543g (170)	518g (170)	493g (170)
Weight (L)	211g (170)	211g (170)	211g (170)	211g (170)
Total Average Weight	779g (170)	754g (170)	729g (170)	704g (170)

Bottom Brackets

Model No.	BBS18	BBS15
Type	Square Taper	Square Taper
Material	Axle	Steel
	Cups	Aluminum
	Sleeve	Aluminum (Cylindrical)
	Stopper	Engineering Polymers
Bearing	Sealed Cartridge x 2	Sealed Cartridge x 2
Cup Thread	(B) BSA: BC1.37x24T	(B) BSA:BC1.37x24T
Shell Width	(S) 68mm	(S) 68mm
Spindle Length	(A) 103mm / (B) 107mm	(A) 103mm / (B) 107mm
Axle Thread	M8 x P1.0	M8 x P1.0
Axle Bolt	Standard: BAS05 / Optional: BAS15	Standard: BAS05 / Optional: BAS15
Finish	(S) Silver Alloy	(C) Chrome
Average Weight	260g (68/L103mm)	338g (68/L103mm)

Chain Tensioners

Model Name	CTS8X		CTS80	CTS70
Model No.	CTS8X SD (B)	CTS8X SD (S)	CTS80 SD (B)	CTS70 SD (B)
Cage Type	(S) Short		(S) Short	(S) Short
Mounting Type	(D) Direct		(D) Direct	(D) Direct
Speeds	Single		Single	Single
Max. Rear Sprocket	25T		25T	25T
Min. Rear Sprocket	18T		18T	18T
Link	Forged 6061 Aluminum		Forged 6061 Aluminum	Forged 6061 Aluminum
Outer Plate Cage	Aluminum / CNC		Aluminum	Steel
Innter Plate Cage	Aluminum		Aluminum	Steel
Bracket Bolt	7075 Aluminum / Gold Anodized		7075 Aluminum / Silver Anodized	7075 Aluminum / Silver Anodized
Guide Pulley	11T / 7075 / Sealed Cartridge Bearing		11T	11T
Tension Pulley	11T / 7075 / Sealed Cartridge Bearing		11T	11T
Applicable Dropout Width	5~9mm		5~9mm	5~9mm
Finish	(B) Black	(S) Silver-Black	(B) Black	(B) Black
Average Weight	168g		168g	200 g

Chains

Model	CNS22 (D)	CNS12 (S)	CNS10 (D)	CNS10 (B)
Speed	Single / Internal Gear Hub	Single / Internal Gear Hub	Single / Internal Gear Hub	Single / Internal Gear Hub
Pitch	1/2" x 3/32"	1/2" x 1/8"	1/2" x 1/8"	1/2" x 1/8"
Pin Material	Steel	Steel	Steel	Steel
Pin Power	≥ 80kgf	≥ 150kgf	≥ 80kgf	≥ 80kgf
Roller Material	Steel	Steel	Steel	Steel
Outer Plate Material	SAE1008	SAE1008 / Hollow Plate	SAE1008	SAE1008
Inner Plate Material	SAE1008	SAE1008	SAE1008	SAE1008
Tensile Strength	≥ 820kgf	≥ 920kgf	≥ 820kgf	≥ 820kgf
Finish	(D) Dacromet	(S) Silver Ni	(D) Dacromet	(B) Black
Connect End Pin	●	●	●	●
Connect Guide Pin	×	×	×	×
Connect Easy Link	×	×	×	×

Model	CNX46 (S)	CNX56 (S)	CNX58(S)	CNX59(S)
Speed	Single / Fixed / BMX	Single / Fixed / BMX	Single / Fixed / BMX	Single / Fixed / BMX
Pitch	1/2" x 1/8"	1/2" x 1/8"	1/2" x 3/32"	1/2" x 3/32"
Pin Material	SCM420	Chromized SCM / Hollow Pin	SCM420	Chromized SCM / Hollow Pin
Pin Power	≥ 150kgf	≥ 150kgf	≥ 150kgf	≥ 150kgf
Roller	Steel	SCM435	SCM435	SCM435
Outer Plate Material	SAE1035	SAE1035	SAE1035	SAE1035
Inner Plate Material	SAE1035	SAE1035	SAE1035	SAE1035
Tensile Strength	≥ 1000kgf	≥ 1000kgf	≥ 1000kgf	≥ 1000kgf
Finish	(S) Silver Ni	(S) Silver Ni	(S) Silver Ni	(S) Silver Ni
Connect End Pin	○ (optional)	○ (optional)	○ (optional)	○ (optional)
Connect Guide Pin	CNPX1 (included)	CNPX1 (included)	CNPX3 (included)	CNPX3 (included)
Connect Easy Link	×	×	×	×

Guide Pin

Model	CNPX1	CNPX3
Chain Compatibility	CNX 1/8"	CNX 3/32"
Pin Width	9.6mm	7.8mm

Note

Note

Note

Note

Look for Sun Race 2011-2012 catalogue.

SUNRACE DRIVEN



2011 ~ 2012 / Product Catalogue



1911 point-of-sale advertisement



Sun Race Sturmev-Archer Inc.

No. 51, Hai-Shan-Jung St. Hai-Hu Village,
Lu-Ju City, Taoyuan County, 338 Taiwan
Tel:+886 (3) 354-3900
Fax:+886 (3) 354-2858
E-mail:info@sunrace.com

Sun Race Sturmev-Archer Europe

Keienbergweg 79,
1101GE Amsterdam, The Netherlands
Tel:+31 (20) 609-0221
Fax:+31 (20) 609-0211
E-mail:info@sunrace.nl

Sun Race Sturmev-Archer USA

1436 Second Street, #409
Napa, CA 94559 U.S.A
Tel:+1 (707) 259-6700
Fax:+1 (707) 259-6710
E-mail:info@sunraceusa.com

www.sunrace.com
www.sturmev-archer.com
www.sturmev-archerheritage.com